

# SFXB 雪霸®

— 股权代码：891330 —

## PROFESSIONAL AUTOMATIC

FILLING LINE

### 专业自动灌装生产线



调味品 酱料



化妆品 化工



制药 保健品



2016年9月22日  
在广州股权交易中心正式挂牌



高新技术企业



管理体系认证证书  
MANAGEMENT SYSTEM CERTIFICATE



管理体系认证证书  
MANAGEMENT SYSTEM CERTIFICATE

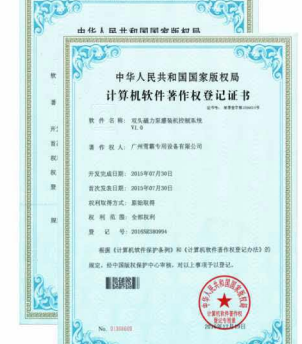
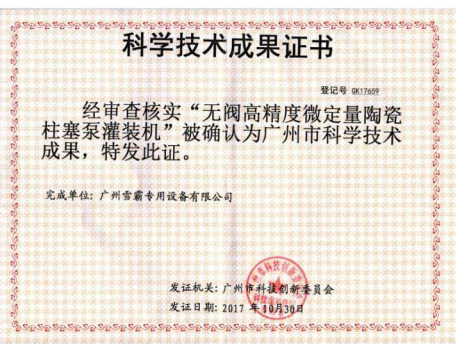

发明专利



## 关于雪霸

广州雪霸专用设备有限公司 座落于广州市南沙区大岗镇, 专注自动化灌装生产线的研发、生产及销售, 2000年以来, 长期结合市场需要, 不断完善创新, 为智能自动化灌装整线设备积累了宝贵的实践经验。能够完成整线各环节设备的开发生产, 生产配套能力强, 是国内为数不多专业从事非标自动化直线灌装生产线设备的领先企业。公司产品体系丰富, 主营: 灌装机、微量陶瓷泵灌装机、铝箔封口机、贴标机、锁盖机及全自动包装生产线等, 为调味品、酱料、饮料、保健品、制药、化妆品等行业配套各类生产线, 已成为多家知名企业的指定生产线配套供应商, 产品质量稳定, 长期销往国内外。



## About Xueba

Guangzhou XueBa Special Equipment Co.,LTD ,Located in Dagang Town, Nansha District, Guangzhou City.We Focusing on the research and development, production and sales of automated filling production lines. Since 2000, factory have been constantly improving and innovating in accordance with market needs for a long time,and have accumulated valuable practical experience for intelligent automated filling line equipment.Our factory has strong capabilities to fulfill Development and production of machines for each Part of the production line,It is one of the few leading companies in China that specializes in customized automatic filling production line and equipment.Our factory have a wide range of product ,Main products are Filling machine, micro ceramic pump filling machine, aluminum foil sealing machine, labeling machine, capping machine and automatic packaging production line etc. We supply Various production lines for condiments, sauces, beverages, health products, pharmaceuticals, cosmetics and other industries,and has been the designated supplier of many well-known companies. Our product quality is good and stable to be Hot selling worldwide.



# 专业设备/品质控制



品质控制 Quality control



三坐标检查仪 3D tester

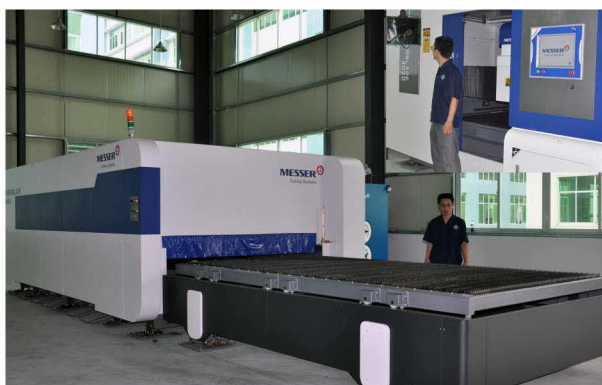

激光切割机  
Laser cutting machine



CNC雕刻机  
CNC engraving machine



数控折弯机  
Numerical control bender



数控机  
Numerical control lathe



CNC加工中心 CNC processing center



活塞缸精密加工  
Precision processing of piston cylinder

## 元器件主要供应商 Main component suppliers

我们与国内外优秀的元件供应商建立长期稳定的友好合作关系，公司将严格遵守供应商管理制度，对每一个元件和材料的采购，都要经过严格的筛选；选择复合质量要求的优秀供应商作为公司长期合作伙伴，与公司一起成长发展。

We have established long-term and stable friendly cooperative relations with excellent component suppliers at home and abroad. The company will strictly abide by the supplier management system. Every component and material purchase must go through strict screening; select excellent suppliers that meet the quality requirements. As the company's long-term partner, grow and develop together with the company.



## 合作伙伴 Cooperation partner



# 目录

Catalog



## 生产线系列

Production Line Series  
P06~16

- 伺服活塞式灌装生产线
- 回转式真空负压灌装生产线
- 称重式灌装生产线
- 跟随式灌装生产线
- 自流式灌装生产线
- 小剂量陶瓷泵灌装生产线



## 灌装机系列

Filling Machine Series  
P17~24

- 活塞式灌装机
- 称重式灌装机
- 真空式灌装机
- 跟随式灌装机
- 自流式灌装机



## 旋盖机/ 压盖机系列

Capping Machine Series  
P25~29

- 变频高速旋盖机
- 四轮旋盖机
- 真空旋盖机
- 回旋式旋盖机/压盖机



## 封口机系列

Sealing Machine Series  
P30~32

- 直线三头封膜机
- 水冷式封口机
- 风冷式封口机



## 贴标机系列

Labeling Machine Series  
P33~40

- 双面贴标机
- 圆瓶贴标机
- 平面贴标机
- 卧滚贴标机
- 星盘定位贴标机



## 送瓶/ 理瓶机系列

Bottle Unscrambler Series  
P41~42

- 理瓶机
- 送瓶机
- 提升机



## 八工位给袋机

Bag packing machine series  
P43~46

- 给袋机(单袋)
- 给袋机(双袋)
- 给袋机应用

# 玻璃瓶灌装包装流程图

Class Bottle Filling Packing Diagram

## 酱类生产线工艺流程简图 Process chart of sauce production line

调配车间 → 酱料 → 调配 → 熬煮 → 高位灌

杀菌 ← 真空检测 ← 真空旋盖 ← 浓酱灌装 ← 酱料

↓  
酱料包装车间

烘干机 → 贴标机 → 贴码机 → 装箱机 → 成品 → 入库

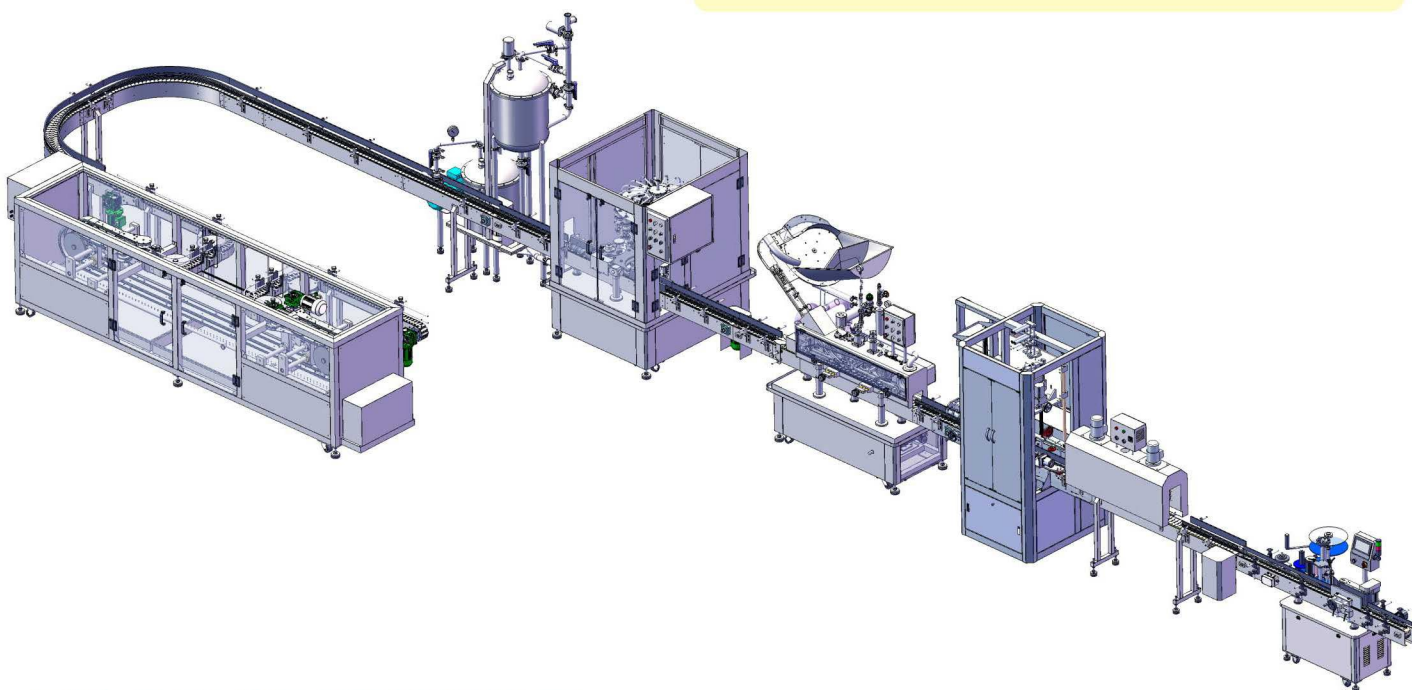

## 果汁生产线工艺流程简图

Process chart of juice production line

原料处理车间

洗果 → 检果 → 破碎 → 打浆 → 榨汁 → 过滤 → 贮存 → 果汁 → 调配 ← 过滤 ← 溶解

↓  
调配车间

均质 → 脱气 → UHT → 成品罐

↓  
储罐

↓  
成品包装车间

喷码 ← 贴标 ← 烘干 ← 杀菌 ← 真空检测 ← 封口 ← 灌装机 ← 烘干

↓  
装箱 → 入库

空瓶 → 洗瓶

## XBGZ-500-12 全自动十二头伺服膏液灌装/旋盖/封口/贴标生产线

12-head Frequency Conversion/Servo Drive Linear Automatic Piston Sauce/ Cream /Liquid Filling Line



**12头伺服灌装线**  
12-head servo filling machine

**8轮上盖旋盖机**  
8-wheel capping machine

**水冷式铝箔封口机**  
Water-cooled aluminum foil sealing machine

**全自动双面贴标机**  
Automatic Dual-side Labeling Machine

### 特点 (Feature)

- 采用先进的人机界面操作, PLC控制;
- 伺服驱动, 人机界面设置灌装量, 使用非常方便; 精密的不锈钢活塞缸加工技术, 确保灌装精准一致, 使密封圈长时间运行不易磨损;
- 物料接触部分均用316L不锈钢材质, 外观304不锈钢, 完全符合食品卫生标准;
- 本设备适用于各种酱料、膏体、液体的灌装, 通用性强。

- Advanced HMI operation, PLC control;

- Frequency conversion/servo drive, HMI for filling volume setting, very convenient for use;
- Precision stainless steel piston cylinder processing technology guarantees accurate and consistent filling, and makes seal ring more durable;
- All material contact parts are made of 316L stainless steel, and surface is made of 304 stainless steel, fully up to related food sanitation standard;
- Suitable for the filling of various sauces, liquid creams and liquids, very versatile.



### 适用范围 (Scope Of Application)

- 食品、医药、化妆品、化工等各种瓶装膏体、液体灌装;
- 各种液体、膏体、酱料 (含软颗粒物) 的灌装, 如 (蜂蜜、辣椒酱、番茄酱、珍珠奶茶、椰果、橙汁等), 通用性强;
- 适合频繁更换物料和清洗要求的客户。

- Suitable for the filling of food, medicine, cosmetics, chemical and other bottled liquid creams and liquids;
- Suitable for the filling of various liquids, liquid creams and sauces with soft particles (e.g. honey, chili sauce, tomato sauce, pearl milk tea, coconut juice, orange juice);
- Suitable for the customers frequently replacing materials and with cleaning requirements.

### 技术参数 Technical parameters

灌装量 (可选) Filling volume (optional)	灌装精度 Filling precision	产量 Output	气压范围 Pressure range	电源 Power supply
120/250/500/1000/2500/5000ml	≤ ±1%	20-60瓶/分 bottles/min (因物料、瓶子大小而异)	0.4~0.6Mpa	AC220/380V 50/60HZ

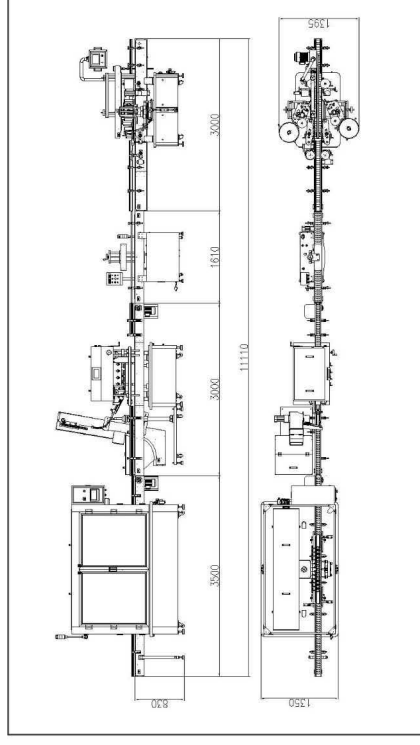



# 十八头 回转式真空灌装/旋盖/贴标生产线(中小口径玻璃瓶)

18 heads rotary vacuum filling/capping/labeling production line (small and medium caliber glass bottles)



十八头回转式灌装机  
18-head rotary filling machine

三四旋盖真空封口机  
Twisting off vacuum capping machine

浆糊贴标机  
Paste labeling machine

## 特点 (Feature)

- 全自动回转式十八头真空灌装, 自动上盖蒸汽喷射排气封口旋盖, 浆糊贴标;
- 按钮开关、旋钮调节、操作易用;
- 采用真空负压差式等液位灌装, 防起泡防滴漏, 旁置独立料灌与灌装阀, 可CIP清洗;
- 物料接触部分均采用316L不锈钢材质, 外观304不锈钢, 完全符合食品卫生标准。

- Full automatic rotary 18-head vacuum filling, automatic capping, steam jet exhaust sealing rotary capping, paste labeling;
- Switch, knob adjustment, easy to operate;
- Vacuum differential pressure equal level filling, bubbling proof and dripping proof, with independent material tank and filling valve aside, CIP cleaning;
- All material contact parts are made of 316L stainless steel, and surface is made of 304 stainless steel, fully up to related food sanitation standard;



## 适用范围 (Scope Of Application)

- 适合中小口径玻璃瓶包装的(三旋、四旋)调味品/酱料灌装;
- 适合液体: 酱油、醋、饮料的灌装; 含颗粒粘稠物料: 辣椒酱、番茄沙司、蚝油的灌装。

- Suitable for the filling of Condiment/sauce adopting small and medium caliber glass bottle packaging (3 twists or 4 twists);
- Suitable for the filling of liquids such as sauce, vinegar and beverage, and the filling of particle-bearing pasty materials such as chili sauce, tomato sauce and oyster sauce.

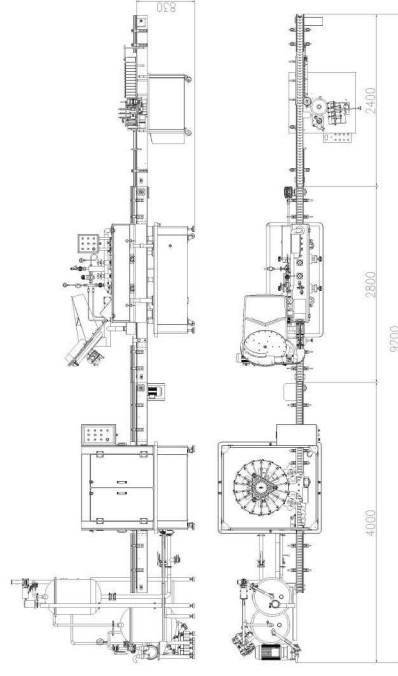

## 技术参数 Technical parameters

灌装量(可选) Filling volume (optional)	灌装精度 Filling precision	产量 Output	气压范围 Pressure range	电源 Power supply
100~2000ml	±3mm(等液位灌装) (equal level)	80-150瓶/分 bottles/min	0.4~0.6Mpa	AC220/380V 50/60Hz

## XBCZ-4/6/8头 全自动称重式液体灌装/旋盖/封口生产线

XBCZ-4/6/8head Automatic weighing liquid filling/capping/sealing production line



### 四头全自动称重式液体灌装机

Automatic four-head weighing liquid filling machine

### 单头伺服旋盖机

Single head servo capping machine

### 风冷式铝箔封口机

Air-cooled aluminum foil sealing machine

#### 特点 (Feature)

- 先进的人机界面操作系统,能自动计数进瓶,计量灌装;
- 设备自动化程度高,每个灌装头均设有称重自动反馈系统,确保计量一致性;
- 物料接触部分均用316L不锈钢材质,外观304不锈钢,完全符合食品卫生标准;
- 灌装头设有特殊防滴漏机构。
- Advanced HMI operating system, PLC control, automatic counting of incoming bottles, weighing and filling
- The equipment has high automation. Each filling head is equipped with the automatic feedback system for weighing to guarantee consistent measuring.
- All material contact parts are made of 316L stainless steel, and surface is made of 304 stainless steel, fully up to related food sanitation standard;
- The filling head is equipped with the special dripping-proof mechanism.

#### 适用范围 (Scope Of Application)

- 食品、医药、化妆品、化工等桶装型的液体称重分装。

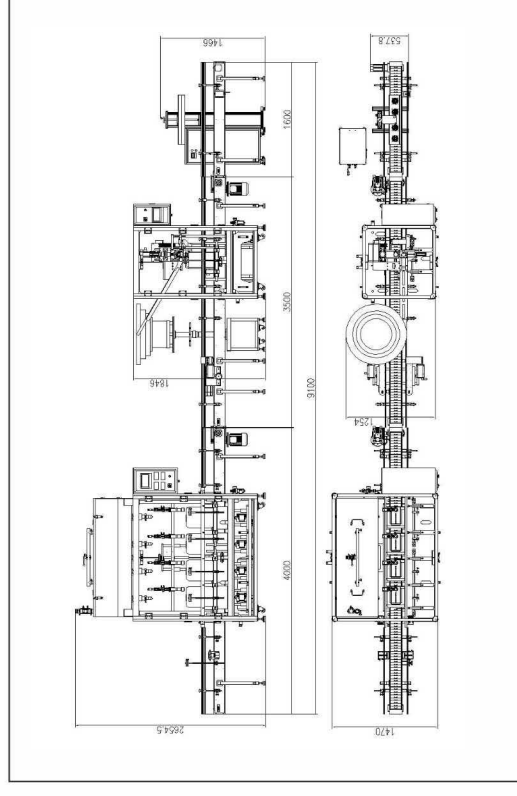

#### 技术参数 Technical parameters

灌装量(可选) Filling volume (optional)	5kg-25kg	灌装精度 Filling precision	± 10g	产量 Output	4-8桶/分 buckets/min	气压范围 Pressure range	0.4~0.6Mpa	电源 Power supply	AC380V/50/60Hz 2300W
--------------------------------------	----------	---------------------------	-------	--------------	--------------------	------------------------	------------	--------------------	----------------------

# 双头 跟随式理瓶/灌装/旋盖/双面贴标机生产线

Double-head follow type bottle unscrambling/filling/capping/double side labeling machine production line



**高速理瓶机**  
Bottle turntable



**双头活塞式跟随灌装机**  
Double-head piston type follow filling machine



**双头跟随式旋盖机**  
Double-head follow capping machine



**全自动双面贴标机**  
Automatic Round Bottle Labeling Machine

## 特点 (Feature)

- 采用先进的人机界面操作, PLC控制;
- EtherCAT总线伺服运动控制系统, 数据反应速度快, 稳定性高, 活塞式定量灌装, 自动跟随边灌边升, 防止物料起泡或溅出;
- 物料接触部分均用316L不锈钢材质, 外观304不锈钢, 完全符合食品卫生标准;
- 设备具有一键切换瓶型功能, 可以适用于不同规格瓶子的自动灌装

- Advanced HMI operation, PLC control;

- EtherCAT bus servo motion control system, fast data response, high stability, piston type quantitative filling, automatically follow the filling and lifting, prevent material bubbling or spatter;

- The contact part of the material is made of 316L stainless steel, and the appearance is 304 stainless steel, which fully meets the food hygiene standards;

- The machine has the function of switching bottle type by one key, which can be used for automatic filling of bottles of different specifications

## 适用范围 (Scope Of Application)

- 食品、医药、化妆品、化工等各种瓶装膏体、液体灌装;
- 各种液体、膏体、酱料(含软颗粒物)的灌装, 如(蜂蜜、辣椒酱、番茄酱、珍珠奶茶、椰果、橙汁等), 通用性强;
- 适合频繁更换物料和清洗要求的客户。

- Suitable for the filling of food, medicine, cosmetics, chemical and other bottled liquid creams and liquids;
- Suitable for the filling of various liquids, liquid creams and sauces with soft particles (e.g. honey, chilli sauce, tomato sauce, pearl milk tea, coconut juice, orange juice);
- Suitable for the customers frequently replacing materials and with cleaning requirements.

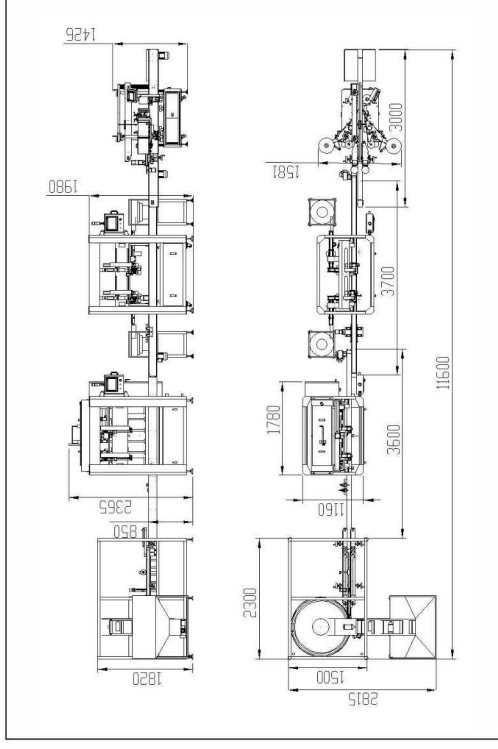

## 技术参数 Technical parameters

灌装量(可选) Filling volume (optional)	灌装精度 Filling precision	产量 Output	气压范围 Pressure range	电源 Power supply
250ml~500ml	±1%	20~50瓶/分 bottles/min	0.4~0.6Mpa	AC220V/380V 50/60HZ 3KW

## XBZLS系列 全自动自流式液体灌装/上盖/旋盖/贴标生产线

XBZLS Series Automatic self-flow liquid filling/capping/capping/labeling production line

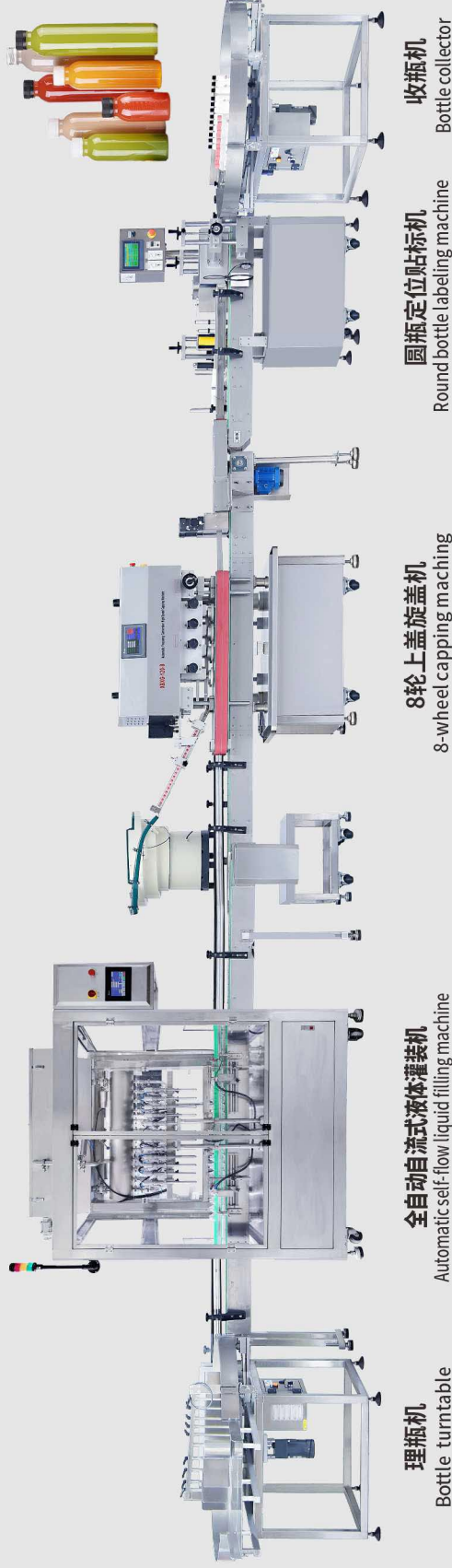

理瓶机  
Bottle turntable

全自动自流式液体灌装机  
Automatic self-flow liquid filling machine

8轮上盖旋盖机  
8-wheel capping machine

圆瓶定位贴标机  
Round bottle labeling machine

收瓶机  
Bottle collector

### 特点 (Feature)

- 采用先进的人机界面操作, PLC控制;
- 物料接触部分均用316L不锈钢材质, 外观304不锈钢, 完全符合食品卫生标准;
- 配有稳压罐, 保证每次灌装压力一样, 从而保证灌装精度; 加大不锈钢料仓, 可配置上料泵, 实现自动上料。
- Adopt advanced man-machine interface operation, PLC control; The contact part of the material is made of 316L stainless steel, and the appearance is 304 stainless steel, which fully meets the food hygiene standards;
- Equipped with a pressure regulator, to ensure that each filling pressure is the same, so as to ensure the filling accuracy;
- Increase the stainless steel bin, can be configured with feeding pump, automatic feeding.

### 适用范围 (Scope Of Application)

- 各种流动性较好的液体灌装。
- It is used for filling of liquids with high liquidity.

### 技术参数 Technical parameters

项目 Items	XBZLS-4	XBZLS-8	XBZLS-12
灌装量 Filling volume		100~1000ml	
灌装速度 Filling speed	10~20瓶/分 bottles/min	20~40瓶/分 bottles/min	30~60瓶/分 bottles/min
灌装精度 Filling precision		±1.5%	
电源 Power supply	AC220V 50/60Hz 1000W	气压范围 Pressure range	0.4~0.6Mpa

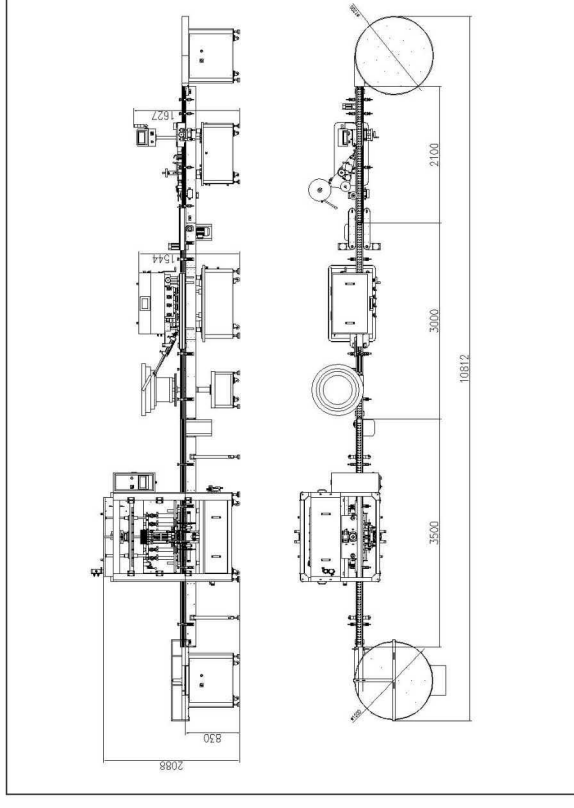

# 十二头 高速直线双列送瓶/灌装/回旋式旋盖/贴标/收瓶生产线

12 heads high speed straight line double row bottle feeding/filling/rotary capping/labeling/bottle receiving production line



**送瓶机**  
Bottle turntable

**十二头双列伺服灌装机**  
Twelve-head double row servo filling machine

**十头回旋式旋盖机**  
Ten-head rotary capping machine

**星盘定点位圆瓶贴标机**  
Astrolabe fixed point positioning round bottle labeling machine

**收瓶机**  
Bottle collector

## 特点 (Feature)

- 采用先进的人机界面操作，PLC控制；
- 变频(伺服)驱动，人机界面设置灌装量，使用非常方便；精密的不锈钢活塞缸加工技术，确保灌装精准一致，使密封圈长时间运行不易磨损；
- 物料接触部分均用316L不锈钢材质，外观304不锈钢，完全符合食品卫生标准。

- Advanced HMI operation, PLC control;
- Frequency conversion/servo drive, HMI for filling volume setting, very convenient for use; Precision stainless steel piston cylinder processing technology guarantees accurate and consistent filling, and makes seal ring more durable;
- All material contact parts are made of 316L stainless steel, and surface is made of 304 stainless steel, fully up to related food sanitation standard;

## 适用范围 (Scope Of Application)

- 食品、医药、化妆品、化工等各种瓶装膏体、液体灌装；
- 各种液体、膏体、酱料的灌装，通用性强；
- 适合频繁更换物料和清洗要求的客户。

- Suitable for the filling of food, medicine, cosmetics, chemical and other bottled liquid creams and liquids;
- Suitable for the filling of various liquids, liquid creams and sauces with soft particles
- Suitable for the customers frequently replacing materials and with cleaning requirements.

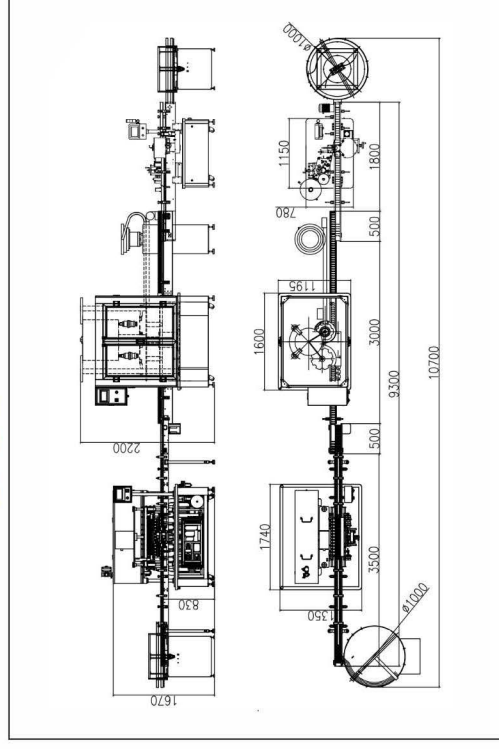

## 技术参数 (Technical parameters)

灌装机(可选) Filling volume (optional)	灌装精度 Filling precision	产量 Output	气压范围 Pressure range	电源 Power supply
15ml~30ml	±1%	80~100瓶/分 bottles/min	0.4~0.6Mpa	AC220V/380V 50/60HZ

## XBGZX-40 小剂量精油陶瓷泵灌装生产线 (送瓶/灌装/上塞/上盖/旋盖/贴标/收瓶)

XBGZX-40 Small-dose essential oil ceramic pump filling production line  
(bottle feeding/filling/plugging/cap-feeding/capping/labeling/bottle collection)



**理瓶转盘**  
Bottle arranging turntable

**陶瓷泵液体自动灌装上塞旋盖机**  
Automatic ceramic pump liquid filling and capping machine

**全自动定位立式圆瓶贴标机**  
Fully automatic positioning vertical round bottle labeling machine

**收瓶转盘**  
Bottle receiving turntable

### 特点

- 采用雪霸高精度陶瓷泵；
- 全自动送瓶、灌装、上塞、上盖、旋盖、贴标一体化；
- 适用小剂量精密定量灌装。

### 适用范围

- 科研院所、实验室、高校、制药厂、化妆品厂等；
- 广泛应用于生物制药、保健品、化工、化妆品等行业的精密定量灌装；
- 用于血液、生物试剂、口服剂、注射液、高级化妆品、精华液、电子烟油、杀菌剂等液体的精密定量灌装；
- 用于各种酸碱腐蚀性液体的精密定量灌装。

### Feature

- SFXB highly-pure, highly-clean and corrosion-resistant valveless ceramic pump is adopted;
- Automatic bottle feeding, filling, plugging, cap feeding, screwing and labeling are integrated;
- Suitable for small-dose precise quantitative filling

### Scope Of Application

- Scientific research institute, laboratory, colleges and universities, pharmaceutical factory, cosmetics factory, etc.
- Widely applied to precision quantitative filling of industries such as medicine, pharmacy, food, chemistry, cosmetics, etc.
- Precision quantitative filling of liquids such as blood, biological reagents, oral agents, injections, advanced cosmetics, fragrances, electronic cigarette oils, fungicides, etc.
- Used for precision quantitative filling of all kinds of acid and alkali corrosive liquid.

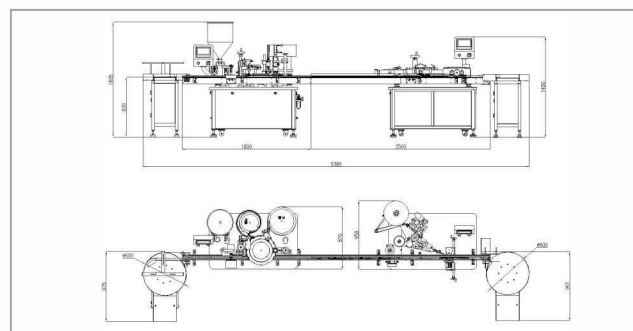

### 技术参数 Technical parameters

灌装量(可选) Filling volume (optional)	灌装精度 Filling precision	产量 Output	气压范围 Pressure range	电源 Power supply
12ml/rev	±0.5%	40瓶/分 bottles/min	0.4~0.6Mpa	AC220V 50/60Hz 2000W

## **XBGX-XH-2A-1 双头灌装上盖旋盖一体机**

XBGX-XH-2A-1 Double Head Cap Sending And Cap Screwing Machine



## **SFGX-1 桶装大装量单头灌装自动上盖旋盖一体机**

SFGX-1 Barreled Large-volume Single-head Automatic Capping and Cap-screwing Integrated Filling Machine





**八轮变频旋盖/铝箔感应封口/贴标装生产线**  
Eight-wheel frequency conversion capping/ aluminum foil induction sealing/ labeling production line



**八头气动直线自动活塞式广口瓶灌装/上盖/旋盖/浆糊贴标生产线**  
Eight-head pneumatic linear automatic piston filling wide mouth bottle filling/capping/capping/paste labeling production line



**十二头全自动辣椒酱送瓶/灌装/上盖/真空旋盖/贴标生产线**  
12 heads automatic bottle feeding/filling/capping/vacuum capping/labeling production line for pepper sauce



**十六头负压等液位灌装/真空旋盖/浆糊贴标生产线**  
16 heads negative pressure equal liquid level filling/ vacuum capping/ paste labeling production line





**双面贴六头灌装/压盖/瓶口收缩生产线**

Double-sided labeling six heads filling cap bottle mouth shrinkage production line



**双头颗粒灌装/八头灌装/压盖生产线**

Double-head granule filling + eight-headed filling and capping production line



**六头磁力泵液体灌装/旋盖/贴标生产线**

6 heads magnetic pump liquid filling/capping/labeling production line



**双头等液位理瓶/灌装/压塞/贴标/收瓶生产线**

Double-head equal-level bottle unscrambling/filling/pressing/plugging/labeling and receiving production line

# XBGG系列 全自动多头伺服驱动活塞式灌装机

XBGGseries Automatic servo driven piston filling machine



**XBGG-500-20-2 双道伺服驱动活塞式灌装机**  
Double channel servo driven piston filling machine

## 特点

- 采用先进的人机界面操作, PLC控制;可双道灌装, 使灌装速度, 生产能力大大提升;
- 物料接触部分均用316L不锈钢材质, 外观304不锈钢, 完全符合食品卫生标准;
- 精密的不锈钢活塞缸加工技术, 确保灌装精准一致, 使密封圈长时间运行不易磨损;
- 伺服驱动, 人机界面设置灌装量, 清洗简便;
- 本设备适用于各种酱料、膏体、液体的灌装, 通用性强。

## 适用范围

- 各种液体、膏体、酱料(含软颗粒物)的灌装, 如(蜂蜜、辣椒酱、番茄酱、珍珠奶茶、椰果、橙汁等), 通用性强。

## Scope Of Application

- Suitable for the filling of various liquids, liquid creams and sauces with soft partides (e.g. honey, chilli sauce, tomato sauce, pearl milk tea, coconut juice, orange juice), very versatile;

## Feature

- Advanced HMI operation, PLC control;
- Realize optional double track filling, greatly improving filling speed and capacity;
- All material contact parts are made of 316L stainless steel, and surface is made of 304 stainless steel, fully up to related food sanitation standard;
- Precision stainless steel piston cylinder processing technology guarantees accurate and consistent filling, and makes seal ring more durable;
- Frequency conversion drive, HMI for filling volume setting, very convenient for washing;
- Suitable for the filling of various sauces, liquid creams and liquids, very versatile.

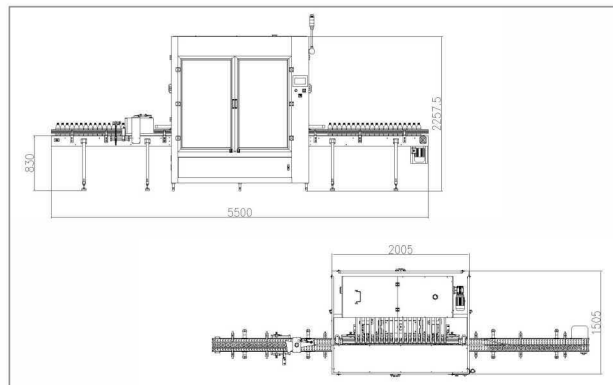



**XBGG-500-8 全自动八头伺服驱动活塞式灌装机**  
Automatic eight-head servo driven piston filling machine

**XBGG-500-12 全自动十二头伺服驱动活塞式灌装机**  
Automatic twelve-head servo driven piston filling machine

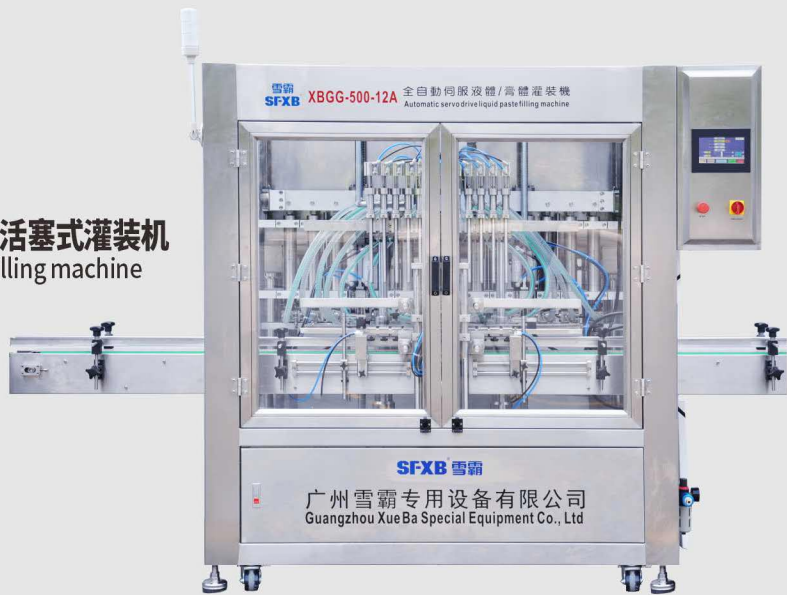

**主要技术参数 Technical Data**

项目 Items	XBGG-120-8	XBGG-500-8	XBGG-1000-8	XBGG-2000-8	XBGG-5000-8
灌装范围 Filling scope	(10~120)ml x 8	(50~500)ml x 8	(100~1000)ml x 8	(250~2500)ml x 8	(500~5000)ml x 8
灌装速度 Filling speed	30~40瓶/分 bottles/min			20~30瓶/分 bottles/min	
灌装精度 Filling precision	≤±1液体 liquid; ≤±2膏体 liquid cream				
气压范围 Pressure range	0.4~0.6Mpa				
电源 Power	AC380V/50/60Hz 3KW		AC380V/50/60Hz 3.5KW	AC380V/50/60Hz 5KW	AC380V/50/60Hz 5.5KW
主机尺寸 Host dimension	1660×1330×2100mm		1940×1330×2100mm	2360×1450×2100mm	2800×1450×2180mm

可选配头数: 4头/6头/8头/12头/16头/18头/20头

可选灌装范围: 120/250/500/1000/2000/5000ml

# XBGZ系列 全自动称重式液体灌装机

XBGZseries Automatic weighing liquid filling machine



## XBCZ-8 全自动八头称重式液体灌装机

Automatic eight-head weighing liquid filling machine

### 特点

- 先进的人机界面操作系统,能自动计数进瓶,计量灌装;
- 设备自动化程度高,每个灌装头均设有称重自动反馈系统,确保计量一致性;
- 物料接触部分均用316L不锈钢材质,外观304不锈钢,完全符合食品卫生标准;
- 灌装头设有特殊防滴漏机构。

### 适用范围

- 食品、医药、化妆品、化工等桶装型的液体称重分装。

### Feature

- Advanced HMI operating system, PLC control, automatic counting of incoming bottles, weighing and filling
- The equipment has high automation. Each filling head is equipped with the automatic feedback system for weighing to guarantee consistent measuring.
- All material contact parts are made of 316L stainless steel, and surface is made of 304 stainless steel, fully up to related food sanitation standard;
- The filling head is equipped with the special dripping-proof mechanism.

### Scope Of Application

- It is used for weighing and filling of liquids in barrels for food, medicine, cosmetics and chemicals.

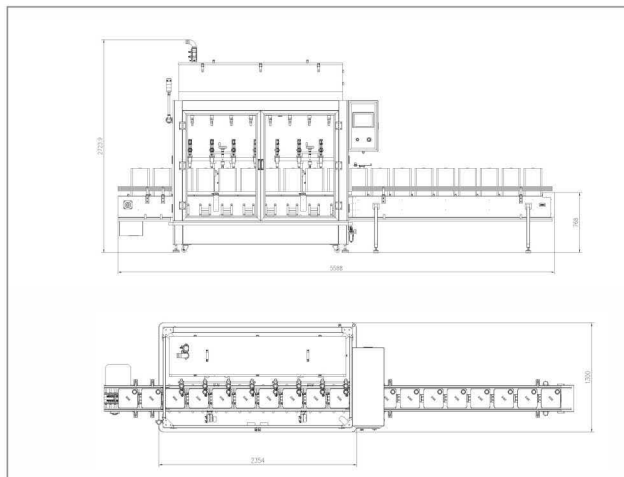



**XBCZ-4 全自动四头称重式液体灌装机**  
Automatic four-head weighing liquid filling machine



**XBCZ-6 全自动六头称重式液体灌装机**  
Automatic six-head weighing liquid filling machine



**主要技术参数 Technical Data**

项目 Items	XBCZ-4	XBCZ-6	XBCZ-8
灌装范围 Filling scope	10kg~25kg		
灌装速度 Filling speed	0~4桶/分 Barrel/min	0~6桶/分 Barrel/min	0~8桶/分 Barrel/min
灌装精度 Filling precision	±10g		
气压范围 Pressure range	0.4~0.6Mpa		
电源 Power	AC380V/50/60Hz 2500W		
主机尺寸 Host dimension	4000×1470×2652mm	5500*1450*2440	5588×1300×2724mm

# XBKG-18 全自动十八头回转式真空灌装机(中小口径玻璃瓶)

XBKG-18 Automatic 18-head Rotary Vacuum Filling Machine (for Small and Medium Caliber Glass Bottles)



## 特点

- 全自动回转式十八头真空灌装;
- 采用真空压差式等液位灌装, 防起泡防滴漏, 旁置独立料灌与灌装阀, 可CIP清洗;
- 物料接触部分均用316L不锈钢材质, 外观304不锈钢, 完全符合食品卫生标准。

## 适用范围

- 适合中小口径玻璃瓶包装的调味品/酱料灌装;
- 适合液体: 酱油、醋、饮料的灌装; 含颗粒粘稠物料: 辣椒酱、番茄沙司、蚝油的灌装。

## 主要技术参数 Technical Data

项目 Items	XBKG-18
灌装范围 Filling scope	100~2000ml
灌装速度 Filling speed	80~120瓶/分 bottles/min
灌装精度 Filling precision	≤±3mm(液面误差)(liquid level error)
适用瓶高 Applicable bottle height	120~330mm
适用瓶径 Applicable bottle diameter	40~100mm
电源 Power	AC220V/380V 50/60HZ 3KW
气压范围 Pressure range	0.4~0.6Mpa
重量 Weight	1500kg
主机尺寸 Host dimension	3000×1475×1620mm

## Feature

- Automatic rotary 18-head vacuum filling;
- Vacuum differential pressure equal level filling, bubbling proof and dripping proof, with independent material tank and filling valve aside, CIP cleaning;
- All material contact parts are made of 316L stainless steel, and surface is made of 304 stainless steel, fully up to related food sanitation standard;

## Scope Of Application

- Suitable for the filling of seasoning/sauce adopting small and medium caliber glass bottle packaging;
- Suitable for the filling of liquids such as sauce, vinegar and beverage, and the filling of partide-bearing pasty materials such as chilli sauce, tomato sauce

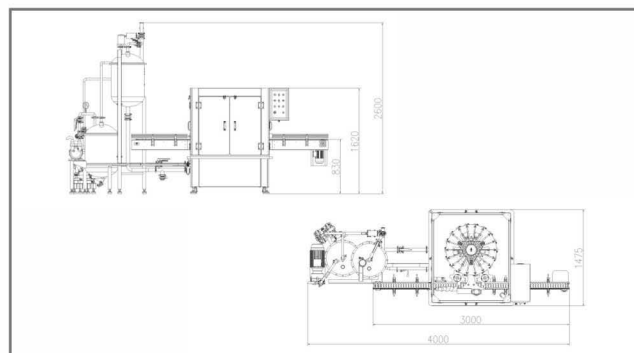

# XBDYW-16 全自动十六头负压式膏液灌装机(玻璃瓶)

## XBDYW-16 Automatic Negative Pressure Type Liquid Cream Filling Machine (Glass Bottle)

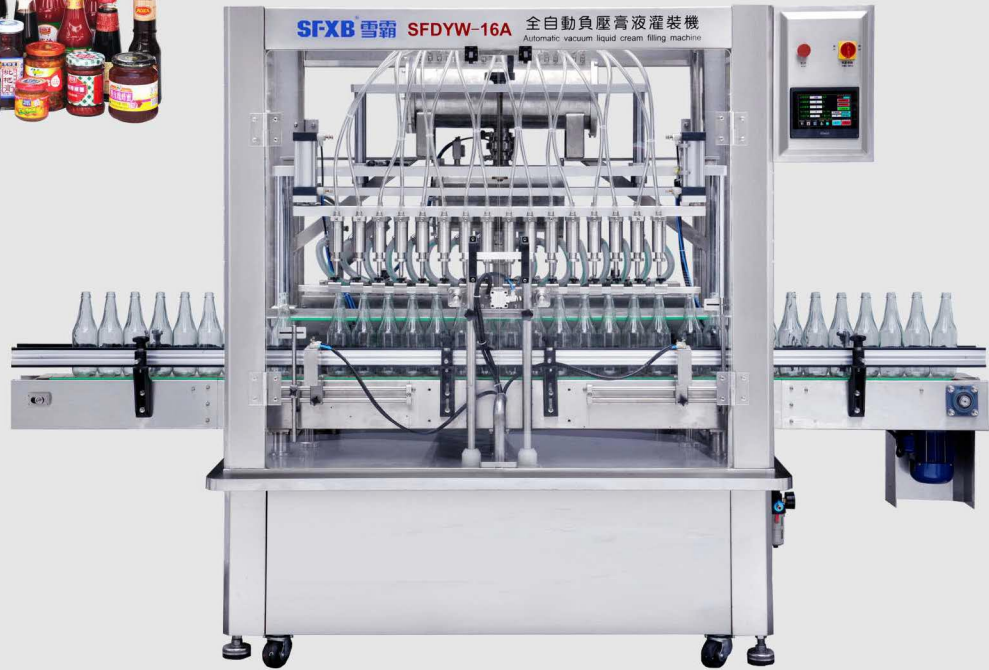

### 特点

- 采用先进的人机界面操作,PLC控制;
- 采用真空负压灌装技术,结构紧凑合理,防起泡、防滴漏;
- 物料接触部分均用316L不锈钢材质,外观304不锈钢,完全符合食品卫生标准。

### 适用范围

- 适合液体:酱油、醋、饮料的灌装;含颗粒粘稠物料:辣椒酱、番茄沙司、蚝油的灌装。

### 主要技术参数 Technical Data

项目 Items	XBDYW-16	
灌装范围 Filling scope	80~500ml	500~2000ml
灌装速度 Filling speed	60-80瓶/分 bottles/min	30-60瓶/分 bottles/min
灌装精度 Filling precision	≤±3mm(液面误差)(liquid level error)	
瓶径规格 Bottle specification	瓶径Bottle diameter Φ38-100mm 瓶高Bottle height Φ65-260mm	
气压范围 Pressure range	0.4~0.6Mpa	
电源 Power	AC220V/50/60Hz 500W	
主机尺寸 Host dimension	3000×1250×1950mm	

### Feature

- Advanced HMI operation, PLC control;
- Vacuum negative pressure filling, compact, bubbling proof and dripping proof;
- All material contact parts are made of 316L stainless steel, and surface is made of 304 stainless steel, fully up to related food sanitation standard;

### Scope Of Application

- Suitable for the filling of liquids such as sauce, vinegar and beverage, and the filling of particle-bearing pasty materials such as chilli sauce, tomato sauce and oyster sauce.

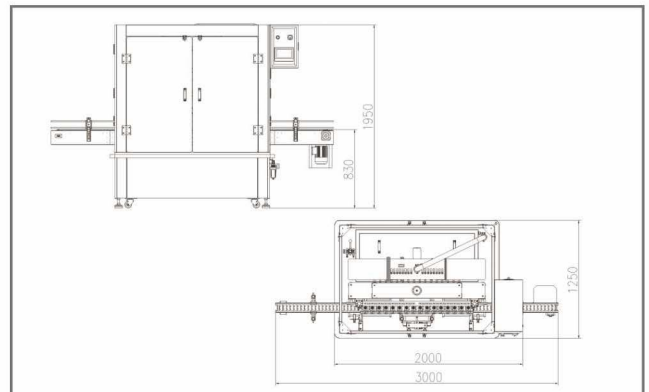

## 双头活塞跟随式灌装机

### Double-head piston tracing filling machine



#### 特点

- 触摸式人机操作界面 可进行远程监控 按键操作, 使用简单;
- EtherCAT 总线伺服运动控制系统 数据反应速度快、稳定性高, 活塞式定量灌装, 边灌边升, 防止物料起泡或溅出;
- 采用真空回吸, 防止物料滴漏 自动跟随灌装;
- 物料接触部分均用316L不锈钢材质, 外观304不锈钢, 完全符合食品卫生标准。

#### 适用范围

- 各种液体、膏体、酱料(含软颗粒物)的灌装, 如(蜂蜜、辣椒酱、番茄酱、珍珠奶茶、椰果、橙汁等), 通用性强。

#### 主要技术参数 Technical Data

项目 Items	双头活塞跟随式灌装机
灌装范围 Filling scope	200~500ml
灌装速度 Filling speed	20~40瓶/分 bottles/min
灌装精度 Filling precision	±1%
气压范围 Pressure range	0.4~0.6Mpa
电源 Power	AC220V/380V 50/60HZ 6KW
主机尺寸 Host dimension	3600×1160×2365mm

#### Feature

- Advanced HMI and touch keys operation , can realize remote monitoring operation, easy to use;
- Adopt EtherCAT master servo motion control system which have the advantages of fast data feedback and High stability; using piston quantitative filling , filling and lifting at the same time to prevent material from bubbling or spatter;
- Vacuum suction is adopted to prevent material from dripping and realize Automatic tracing filling;
- The contact part of the material is made of 316L stainless steel, and the appearance is 304 stainless steel, which fully meets the food hygiene standards;

#### Scope Of Application

- Suitable for the filling of various liquids, liquid creams and sauces with soft particles (e.g. honey, chilli sauce, tomato sauce, pearl milk tea, coconut juice, orange juice), very versatile;

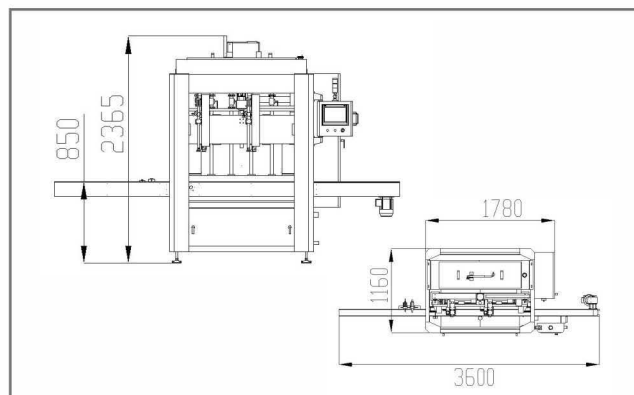



# XBZLS-8/12头 全自动头自流式液体灌装机

## Automatic 8/12 heads self-flowing liquid filling machine



**XBZLS-12**



**XBZLS-8**

### 特点

- 先进的人机界面操作系统;
- 灌装量, 人机界面设置流量, 操作简便;
- 物料接触部分均用316L不锈钢材质, 外观304不锈钢, 完全符合食品卫生标准。

### 适用范围

- 各种流动性较好的液体灌装。

### Feature

- Advanced HMI operating system
- Filling flow is set by HMI and operation is easy.
- All material contact parts are made of 316L stainless steel, and surface is made of 304 stainless steel, fully up to related food sanitation standard.

### Scope Of Application

- It is used for filling of liquids with high liquidity.

### 主要技术参数 Technical Data

项目 Items	XBZLS-8	XBZLS-12
灌装范围 Filling scope	50~2000ml	
灌装速度 Filling speed	20~70瓶/分 bottles/min	30~100瓶/分 bottles/min
灌装精度 Filling precision	±1.5%	
气压范围 Pressure range	0.4~0.6Mpa	
电源 Power	AC380V/50/60Hz 500W	
主机尺寸 Host dimension	3000×1080×2451mm	3000×1070×2131mm

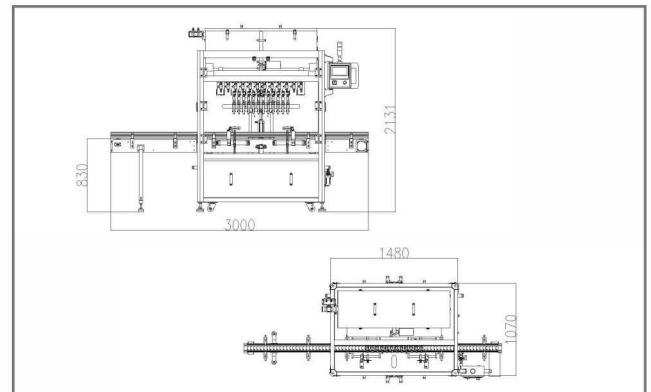

# XBXG-120-8 全自动变频高速旋盖机

## XBXG-120-8 Automatic Frequency Conversion High-speed Capping Machine



### 特点

- 采用先进的人机界面操作,PLC控制, 304不锈钢外观;
- 运动中8轮旋盖, 旋盖速度快, 并能有效地避免防盗盖断裂和对瓶盖的损伤;
- 只需调整同步带、旋盖轮的间距及机架高度即可适应在适用范围内各种规格的瓶子而无需更换部件;
- 适用于各种高低瓶, 瓶体类形为圆形、方形、扁圆或扁方的各类瓶子。

### 适用范围

- 各种圆瓶、方瓶、扁圆瓶旋盖;
- 可独立机架式使用, 适应客户大型生产线旋盖需求;
- 适合要求更换不同规格类型瓶子的客户。

### 主要技术参数 Technical Data

项目 Items	XBXG-120-8
瓶盖直径 Cap diameter	Φ19-120mm
瓶体直径 Bottle diameter	Φ20-150mm
瓶子高度 Bottle height	45-320mm
旋盖速度 Screwing speed	30-80瓶/分 bottles/min
电源 Power	AC220V 50/60HZ 2500W
气压范围 Pressure range	0.4~0.6Mpa
主机尺寸 Host dimension	3000x830x2200mm
上盖机尺寸 Dimension of capping machine	1060 x560 x2300mm

### Feature

- Advanced HMI operating system, PLC control, 304 stainless steel surface;
- 8-wheel capping in operation makes the screwing speed fast and effectively avoids theft-proofing cap breakage and damage to the bottle caps.
- It is possible to cater to varied bottle caps within the scope of this machine without replacement of parts by simply adjusting the synchronous belt, distance between cap screwing wheels and rack height.
- It applies to varied tall and short bottles which are round, square, oblate or flat square in shape.

### Scope Of Application

- It is used for cap screwing of round bottles, square bottles or oblate bottles.
- It can be used on the independent rack and is suitable for cap screwing at large scale production lines of customers.
- It applies to customers requiring replacement of different specifications of bottles.

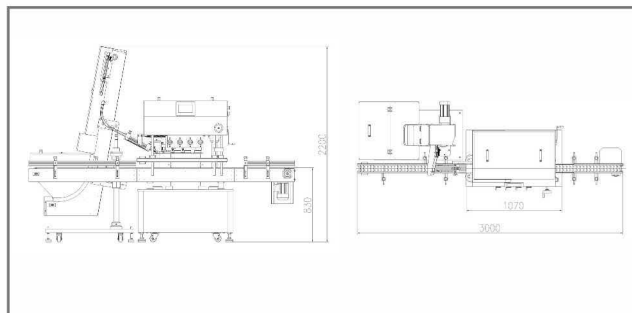



**全自动四轮旋盖机**  
Automatic four wheel capping machine



**主要技术参数 Technical Data**

锁瓶高度 Capping height	50~300mm
旋盖速度 Screwing speed	10~60瓶/分 bottles/min
气压范围 Pressure range	0.4~0.6Mpa
电 源 Power	AC220V 50/60HZ 1000W
主机尺寸 Host dimension	2700 x 736 x 1486mm



**XBZY-100 全自动压盖机**  
XBZY-100 Automatic Capping Machine



**XBZY-80 全自动压盖机**  
XBZY-100 Automatic Capping Machine

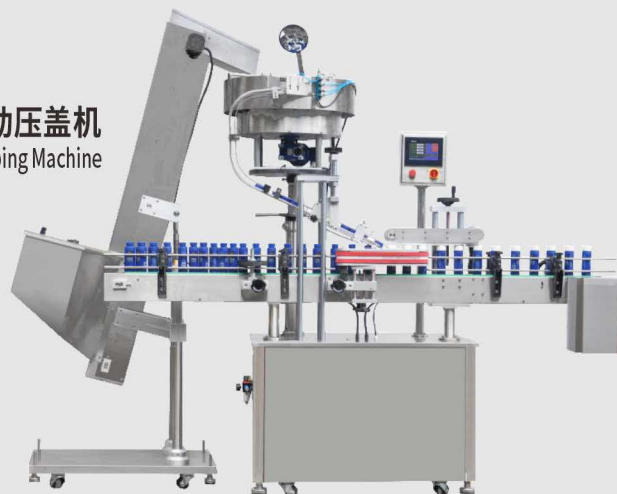

**主要技术参数 Technical Data**

项 目 Items	XBZY-80/100
瓶盖/瓶身直径 cap/body diameter	Φ20-100mm
瓶子高度 Bottle height	100-320mm
压盖速度 Capping speed	60-100瓶/分 bottles/min
气压范围 Pressure range	0.4~0.6Mpa
电 源 Power	AC220V 50/60HZ 1000W
主机尺寸 Host dimension	3000 x 1517 x 2381mm

# XBKX-200 三四旋盖真空封口旋盖机

XBKX-200 Twist-off Cap Vacuum Capping Machine



## 特点

- 采用自动真空旋盖封口于一体，自动化程度高；
- 采用变频调速、蒸汽喷射排气和机械封盖机构，功能齐全；
- 整机304不锈钢外观结构，具有良好的性能，易于操作，造型美观。

## 适用范围

- 适用于各种玻璃瓶装调味品、酱菜、腐乳、果酱等产品的真空封口旋盖。

## 主要技术参数 Technical Data

项目 Items	XBKX-200
瓶盖直径 Cap diameter	Φ38-100mm
瓶体直径 Bottle diameter	Φ38-82mm
瓶子高度 Bottle height	65-260mm
旋盖速度 Screwing speed	80-150瓶/分(因瓶而异) bottles/min (depending on bottle)
蒸汽用量 Steam consumption	180-230kg/h
蒸汽压力 Steam pressure	≤0.4MPa
最大真空度 Max vacuum degree	67KPa
电源 Power	AC220V 50/60HZ 3.12KW
重量 Weight	1100kg
气压范围 Pressure range	0.4-0.6Mpa
主机尺寸 Host dimension	2800 x 800 x 1670mm

## Feature

- Automatic vacuum cap screwing and sealing integration; high automation;
- Frequency control, steam jet exhaust as well as mechanical sealing mechanism are adopted; its functions are complete.
- The whole machine is of the 304 stainless steel structure, featuring good performance, easy operation and beautiful shape.

## Scope Of Application

- It applies to cap screwing for vacuum sealing of glass bottled products such as seasoning, pickles, fermented bean curd and jam.

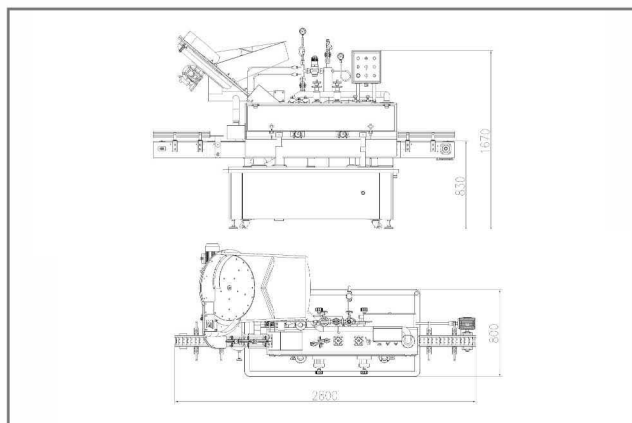

# XBXG-6/8/10头 自动回转式旋盖/压盖机

## 6/8/10 heads automatic rotary cap-clinching machine



### 特点

- 采用先进的人机界面操作,PLC控制;304不锈钢外观结构;
- 设备可根据客户要求的瓶样、产量设计不同数量的机械旋盖(压盖)工位。全程做到自动进瓶、理盖、送盖、抓盖、旋盖(压盖);
- 旋盖松紧程度采用磁力扭矩旋盖,可根据不同盖子调节磁力,达到松紧理想程度;
- 旋盖速度:稳、准、快、成品率高。

### 适用范围

- 适用于各种酒类、食品、饮料、酱醋调味品、医药、化工、农药、试剂等自动包装流水线上配套。
- 适用于各类玻璃瓶或塑料瓶的自动封口包装。
- 可与各种高速灌装机配套使用。

### 主要技术参数 Technical Data

项目 Items	XBXG-6/8/10
瓶盖直径 Cap diameter	Φ18-Φ35mm
瓶体直径 Bottle diameter	Φ18-Φ90mm
瓶子高度 Bottle height	30mm-290mm
旋盖速度 Screwing speed	100-200瓶/分(bottles/min)
电源 Power	AC380V50/60HZ 3000W
气压范围 Pressure range	0.4~0.6Mpa
主机尺寸 Host dimension	4000*1195*2000mm

### Feature

- Adopt advanced man-machine interface operation, PLC control; 304 stainless steel appearance structure;
- The equipment can design different number of mechanical capping (capping) stations according to the bottle sample and output required by customers. The whole process is automatic bottle feeding, cap management, cap feeding, cap grasping, cap screwing (cap pressing).
- The tightness of the screw cap adopts magnetic torque screw cap, the magnetic force can be adjusted according to different caps to achieve the ideal tightness.
- Capping speed: stable, accurate, fast, high yield.

### Scope Of Application

- Suitable for all kinds of wine, food, beverage, sauce and vinegar condiment, medicine, chemical industry, pesticides, reagents and other automatic packaging line supporting.
- It is suitable for automatic sealing packing of all kinds of glass bottles or plastic bottles.
- It can be used with various high-speed filling machines.

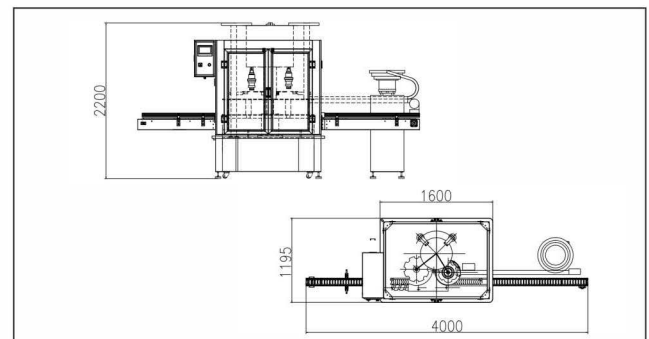

# XBZK-2 全自动双头跟随式真空旋盖机

## Automatic following two-heads type vacuum capping machine



### 特点

- 采用先进的人机界面操作，PLC控制，确保无盖无瓶自动停机报警；
- 自动上盖抽真空旋盖于一体；
- 旋盖扭力及真空度可按需设定，可确保真空度绝对达标；
- 适用于各种玻璃瓶抽真空旋盖，兼容性强；
- 304不锈钢外观结构。

### 适用范围

- 食品、医药、化妆品、化工等各种玻璃瓶抽真空平面盖压盖旋盖。

### 主要技术参数 Technical Data

项目 Items	XBZK-2(2头 heads)
瓶体直径 Bottle diameter	Φ 60-80mm
瓶子高度 Bottle height	60-140mm
旋盖速度 Screwing speed	40-50瓶/分 bottles/min
拧紧力矩 Tightening torque	可调 Adjustable within
瓶内压强 Intensity of pressure in bottle	≤67Kpa
电源 Power	AC380V 50/60HZ 2100W
气压范围 Pressure range	0.4-0.6Mpa
主机尺寸 Host dimension	3207 x 1096 x 2100mm

### Feature

- Advanced HMI operation and PLC control are adopted to guarantee automatic shut-down and alarm when bottles and caps are inaccessible.
- Automatic screwing and vacuumizing integration Cap screwing torque and vacuum degree can be set as required to make vacuum degree conforming.
- It applies to vacuumized cap screwing of varied glass bottles and is highly compatible.
- The surface is made of 304 stainless steel.

### Scope Of Application

- It applies to capping and screwing of vacuum plane caps of glass bottles for food, medicine, cosmetics and chemicals;

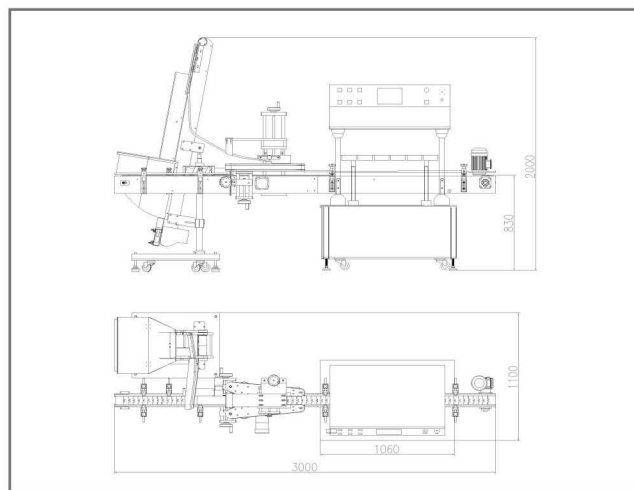

# SFFK-03A 直线式伺服夹送瓶三头卷膜封口机

## Straight-line servo bottle clipping and feeding three-head winding film sealing machine

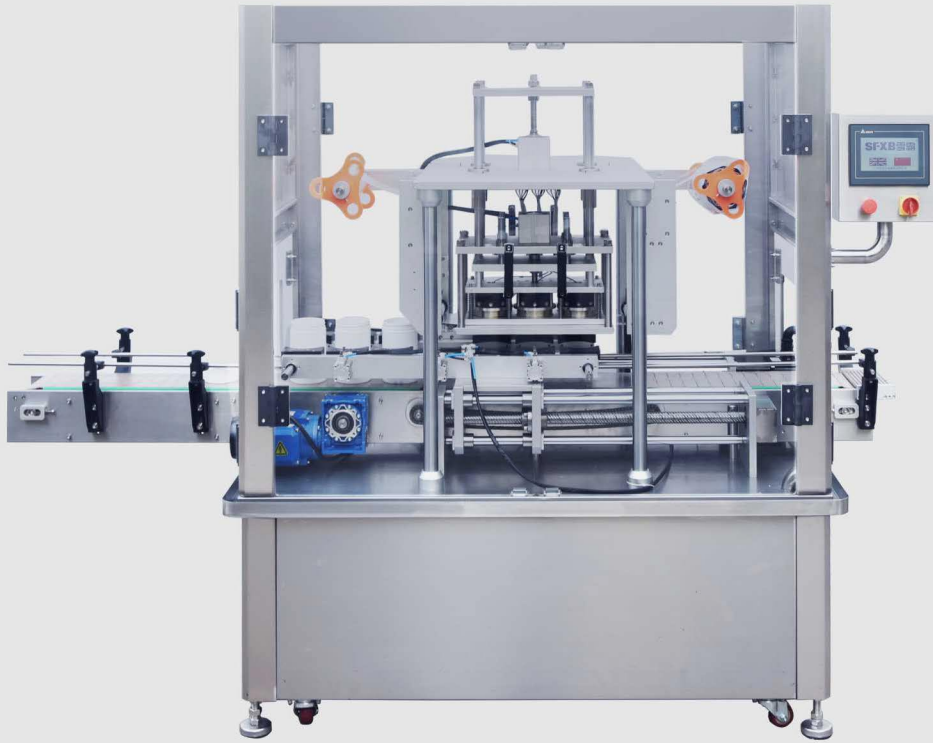

### 特点

- 采用先进的人机界面操作,PLC控制;304不锈钢外观结构;
- 采用卷膜封切式热封口,耗材成本低;
- 采用瞬间直热式加热封口对容器内的物品受热影响小;
- 采用伺服夹送瓶提高封口速度。

### Feature

- Adopt advanced man-machine interface operation, PLC control; 304 stainless steel appearance structure;
- Adopting hot sealing and cutting type, low cost of consumables;
- The instant direct heating sealing has little effect on the heating of the objects in the container;
- Servo clip bottle to improve sealing speed.

### 适用范围

- 适用于广口塑料瓶型(圆形、方形、多边形)的卷膜热封口。

### Scope Of Application

- Suitable for hot sealing of wide plastic bottle (round, square polygon)

### 主要技术参数 Technical Data

项目 Items	SFFK-03A
瓶口直径 Bottle mouth diameter	Φ100mm
封口速度 Sealing speed	27瓶/分(bottles/min)
电源 Power	AC220V 50/60HZ 4KW
气压范围 Pressure range	0.4~0.6Mpa
主机尺寸 Host dimension	2500*1056*1846mm

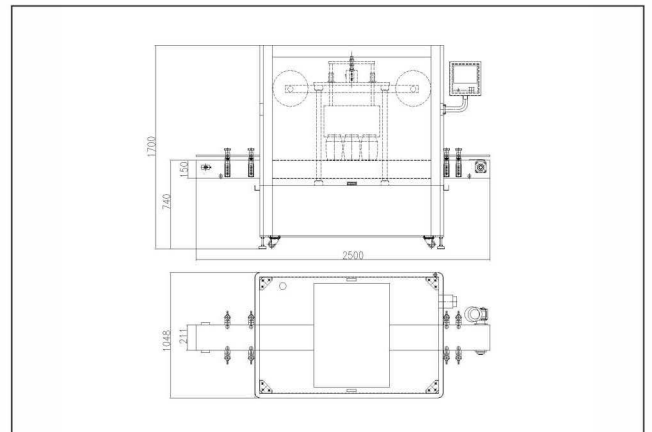

# SF-3000/SF-2900 水冷式自动电磁感应铝箔封口机

## SF-3000/SF-2900 Water-cooled Automatic Electromagnetic-induction Aluminum Foil Sealing Machine



SF-3000



SF-2900

### 特点

- 数码显示工作电压、电流，直观清晰；带有故障提示报警功能；
- 旋钮调节，按钮开关，操作易用，304不锈钢外观；
- 设有断水、过流过压自动保护，安全可靠；
- 封口头采用手轮式升降调节，使用简便；
- 采用水冷循环冷却系统，确保封口产品的稳定性和一致性；
- 电子元器件均采用国际一线品牌产品，可靠稳定，耐用性强；
- 封口速度快、性能稳，可配置无铝箔检测剔除器。

### 适用范围

- 食用、医用、化妆品、日化等各种圆瓶、方瓶、异形瓶等铝箔封口；
- 封口速度快，适合大批量产品生产；
- 分体式结构，可配输送机使用或在原有生产线上实现铝箔封口；
- 可根据客户样瓶选配设计封口头样式（平板式或隧道式）。

### Feature

- Its display digitally indicates operating voltage and current directly and clearly and gives failure warning.
- Its adjustable knob and button type switches are easy to operate. 304 stainless steel exterior.
- Its automatic protection against excessive current and voltage is safe and reliable.
- The height of its sealing tip is easy to adjust using a hand wheel.
- The use of a water circulating cooling system ensures the reliability and consistency of sealed products.
- Made by international top manufacturers, all the electronic components are reliable, stable and highly durable.
- It is characterized by high sealing rate and reliable performance. An optional no-foil detecting eliminator is available upon user's request.

### Scope Of Application

- It may be used for the aluminum foil sealing of all kinds of round, square and special shaped bottles for foods, medicines, cosmetics, daily chemicals, etc.
- Its high sealing rate can meet the requirement for mass production.
- Its split structure allows use of a conveyor in combination or aluminum foil sealing on the original production line.
- The type of the sealing lip (plate or tunnel type) can be customized upon user's request.

### 技术参数 Technical parameters

项目 Items	SF-3000/SF-2900	冷却方式 Cooling type	水冷 (Water-cooling)
供电 Power	AC220V 50/60Hz 3000W	主机尺寸 Size of host machine	570×430×1200mm 1810×458×1300mm
封口直径(选配) Sealing diameter(optional)	Ø50~121mm	包装尺寸 Packing size	1945×595×1545mm 1945×959×1545mm
封口速度 Sealing rate	0~300瓶/分 (bottles/min)	主机重量 Weight	75kg/125kg
传送带速度 Conveyor belt speed	0~20.5±0.5米/分 (m/min)		



# SF-2300/SF-2100 风冷式自动电磁感应铝箔封口机

## SF-2300/SF-2100 Air-cooled Automatic Electromagnetic-induction Aluminum Foil Sealing Machine



SF-2300



SF-2100

### 特点

- 数码显示工作电压、电流，直观清晰，304不锈钢外观；
- 旋钮调节，按钮开关，操作易用；
- 设有过流过压自动保护，安全可靠；
- 封口头采用手轮式升降调节，使用简便；
- 风冷却，性能接近水冷式机效果，封口质量佳；
- 封口速度快、性能稳，可配置无铝箔检测剔除器。

### 适用范围

- 食用、医用、化妆品、日化等各种圆瓶、方瓶、异形瓶等铝箔封口；
- 封口速度快，适合大批量产品生产；
- 分体式结构，可配输送机使用或在原有生产线上实现铝箔封口；
- 可根据客户样瓶选配设计封口头样式（平板式或隧道式）。

### Feature

- Its digital indication of operating voltage and current is visibly legible. 304 stainless steel exterior.
- Its adjustable knob and button type switches are easy to operate.
- Its automatic protection against water supply failure as well excessive current and voltage is safe and reliable.
- The height of its sealing tip is easy to adjust using a hand wheel.
- It features good quality as well as an air cooling effect close to that of a water cooled unit.
- It is characterized by high sealing rate and reliable performance. An optional no-foil detecting eliminator is available upon user's request.

### Scope Of Application

- It may be used for the aluminum foil sealing of all kinds of round, square and special shaped bottles for foods, medicines, cosmetics, daily chemicals, etc.
- Its high sealing rate can meet the requirement for mass production.
- Its split structure allows use of a conveyor in combination or aluminum foil sealing on the original production line.
- The type of the sealing lip (plate or tunnel type) can be customized upon user's request.

### 技术参数 Technical parameters

项目 Items	SF-2300/SF-2100		冷却方式 Cooling type	风冷 (Air-cooling)
供电 Power	AC220V 50/60Hz 4500W		主机尺寸 Size of host machine	1115×365×500mm 1500×400×1255mm
封口直径(选配) Sealing diameter(optional)	Ø15~60mm	Ø50~121mm	包装尺寸 Packing size	1155×580×445mm 1580×420×880mm
封口速度 Sealing rate	0~280瓶/分 (bottles/min)		主机重量 Weight	40kg/75kg
传送带速度 Conveyor belt speed	0~20.5±0.5米/分 (m/min)			



### 特点

- 标头六维空间调整,强大而灵活的调节能力,任何产品的准确标贴都可在几分钟内调整完毕;
- 主动轴与压辊之间的压力可调节,可以使标签纸行进方向任意调节,而不是普通的弹性压紧,标签跑起来“听之任之”;
- 出标头采用双压辊结构,确保标签纸拉紧又避免了因底纸模切损伤而产生的断标现象,分段式离合器使张力更架均衡;
- 主要采用名厂伺服马达,实现闭环控制,满足高速高精度定位;
- 采用特殊设计的整形机构,确保被贴物的准确定位,实现精确贴标;
- 压带与主机齿轮连接,保证了两条传送带绝对同步,而无需任何调整;
- 可按需要附加圆瓶、方瓶多面裹贴的贴标机构,实现一机多用,满足扁瓶贴、圆瓶圆周贴、圆瓶定位贴及多方瓶多面贴;
- 采用先进的人机界面操作,PLC控制,304不锈钢外观结构;操作工人稍加培训即可使用。

### 适用范围

- 适用于方形或扁形物体的双面或单面贴标。

### Feature

- Header is adjusted within 6D space; adjusting capacity is powerful and flexible.
- Correct labeling of any product can be adjusted within several minutes.
- Pressure between the driving shaft and pressure roller is adjustable so that the label travelling direction can be adjusted at will; it is not the common elastic pressing; labels can travel without restriction.
- The header-out is a double pressure-roller structure so labels can be tightened while label breakage due to damage of backing paper die-cutting can be avoided. Sectional type clutch makes tension more balanced.
- Famous manufacturer's servo motor is adopted to achieve close-loop control and meet high speed and high precision positioning.
- The sizing mechanism with a special design is adopted to ensure correct positioning of objects to be labeled and realize precise labeling.
- Pressing belt and the host gear are connected to guarantee absolute synchronization of the two conveyance belts without any adjustment.
- It's possible to attach multi-side wrapping labeling mechanism for round and square bottles to realize one machine for multiple purposes and to achieve flat bottle labeling, round bottle circumferential labeling, round bottle positioning labeling and square bottle multi-side labeling.
- Advanced HMI operation, PLC control, 304 stainless steel appearance are adopted. Operators after receiving a simple training can use it.

### Scope Of Application

- It applies to dual-side or single-side labeling of square or flat objects.

# SF-3060 全自动双面贴标机

## SF-3060 Automatic Dual-side Labeling Machine

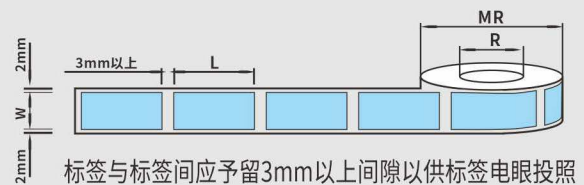
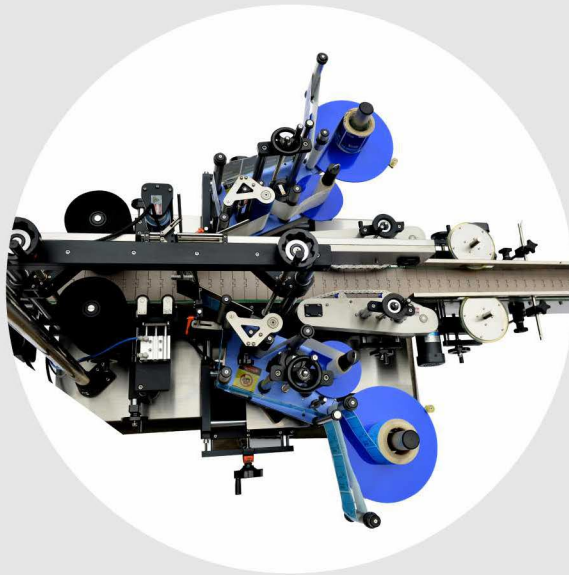

### 主要技术参数 Technical Data

项目 Items	SF-3060
贴标精度 Labeling precision	±1.0mm
贴标速度 Labeling speed	≤100bpm
被贴物尺寸 Size of attached object	长(L)20~300mm 宽(W)20~120mm 高(H)60~320mm
卷标内径(R) Internal diameter of standard coil	Ø76mm
标签卷外径(MR) Outer diameter of label roll	100~350mm
标签卷宽度(W) Width of label roll	10~130mm
标签卷长度(L) Label roll length	15~300mm
气压范围 Pressure range	0.4~0.6Mpa
电源 Power	AC220V 50/60HZ 3000W
主机尺寸 Host dimension	3000 x 1800 x 1540mm

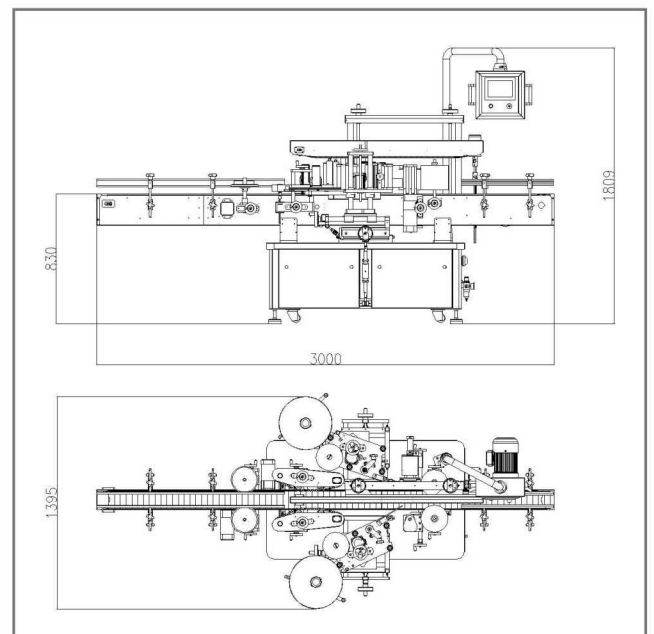

# SF-3030 全自动圆瓶贴标机

## SF-3030 Automatic Round Bottle Labeling Machine



搓滚式覆标机构  
Rolling type label covering mechanism



### 特点

- 采用先进的人机界面操作,PLC控制,可储存生产数据;
- 适合大多数圆瓶或圆柱形物体的贴标,通用性强,304不锈钢外观结构;
- 不锈钢结构,三色警示灯工作状态指示,整机美观大方;
- 新型步进驱动,贴标性能稳定;
- 贴标速度快,适合对贴标精度需求一般的生产需求。

### 适用范围

- 适合大多数圆瓶或圆柱形物体的贴标。

### 主要技术参数 Technical Data

项目 Items	SF-3030
贴标精度 Labeling precision	≤ ±1.0mm
贴标速度 Labeling speed	50~150瓶/分(bottles/min)
圆瓶直径 Round bottle diameter	∅20mm~∅110mm
卷标内径(R) Internal diameter of standard coil	∅76mm
标签卷外径(MR) Outer diameter of label roll	100~350mm
标签卷宽度(W) Width of label roll	10~130mm
标签卷长度(L) Label roll length	15~300mm
电源 Power	AC220V 50/60HZ 800W
主机尺寸 Host dimension	2000 x 905 x 1456mm

### Feature

- Advanced HMI operation, PLC control;
- It applies to labeling of most round or cylindrical objects and is widely applicable. Its appearance structure is made of 304 stainless steel.
- It has the stainless steel (aluminum section) structure and three-color light showing working status; the whole machine is beautiful and decent.
- New step drive, stable labeling performance.
- Labeling speed is fast, suitable for the production demand of labeling accuracy is not high.

### Scope Of Application

- It applies to labeling of most round bottles or cylindrical objects.

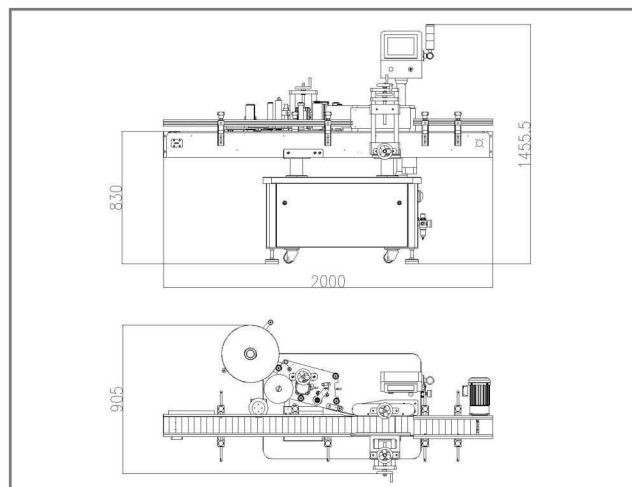

# SF-3040 全自动圆瓶定位贴标机

## SF-3040 Automatic round bottle positioning labeling machine



气缸夹瓶定位机构  
Cylinder clamp bottle positioning mechanism



### 特点

- 采用先进的人机界面操作,PLC控制,可储存生产数据;
- 多规格、多用途,适用于直径不同、高矮不同、硬度不同、透明与不透明的圆瓶、圆柱体的贴标生产工艺,通用性强。
- 304不锈钢外观结构,三色警示灯工作状态指示,整机美观大方;
- 贴标精确、稳定,适合对贴标精度要求高的生产需求。

### 适用范围

- 适合大多数圆瓶、圆柱形物体的贴标。

### 主要技术参数 Technical Data

项目 Items	SF-3040
贴标精度 Labeling precision	≥1.0mm
贴标速度 Labeling speed	20~50瓶/分(bottles/min)
圆瓶直径 Round bottle diameter	Ø20mm~Ø110mm
卷标内径(R) Internal diameter of standard coil	Ø76mm
标签卷外径(MR) Outer diameter of label roll	100~350mm
标签卷宽度(W) Width of label roll	10~130mm
标签卷长度(L) Label roll length	15~300mm
气压范围 Pressure range	0.4-0.6Mpa
电源 Power	AC220V 50/60HZ 800W
主机尺寸 Host dimension	2000 x 815 x 1456mm

### Feature

- Adopt advanced man-machine interface operation, PLC control, can store production data;
- Multi-specification, multi-purpose, suitable for different diameter, different height, different hardness, transparent and opaque round bottle, cylinder labeling production process, strong versatility.
- The appearance of 304 stainless steel structure, three-color warning lamp working status indication, the whole machine is beautiful and generous;
- The labeling is accurate and stable, suitable for the production demand of high labeling accuracy.

### Scope Of Application

- Suitable for labeling most round bottles and cylindrical objects.

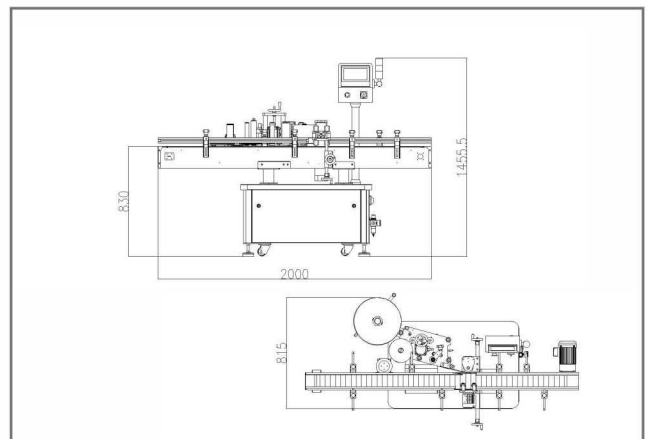

# SF-3020 卧滚贴标机

## SF-3020 Horizontal rolling labeling machine



### 特点

- 标准精度高;送标精准;标带绕行纠偏机构设计,保证标签牵引过程中不左右偏移;
- 无需人工实时监控:标签卷用完前,机器自动声光提醒操作人员更换标签卷,避免缺标签停机耽误生产;
- 换标操作简洁:贴标头各机构设计充分考虑装标的便捷性,大量节省装标签的时间,提高生产效率;
- 流线送标设计:标签在输送过程中采用内包角及流线性设计,避免了硬标签,标签胶水不够或天气寒冷在出标前剥离在送标过程中,降低了生产风险提高了生产效率;
- 自动分瓶机构,适合不能站立的圆形产品的贴标。

### 适用范围

- 适用于细长形圆柱体瓶的圆周表面贴标。

### 主要技术参数 Technical Data

项目 Items	SF-3020
贴标精度 Labeling precision	±1.0mm
贴标速度 Labeling speed	20~250瓶/分(bottles/min)
圆瓶直径 Round bottle diameter	Ø20mm~Ø110mm
卷标内径(R) Internal diameter of standard coil	Ø76mm
标签卷外径(MR) Outer diameter of label roll	100~350mm
标签卷宽度(W) Width of label roll	10~130mm
标签卷长度(L) Label roll length	15~300mm
电源 Power	AC220V 50/60HZ 800W
主机尺寸 Host dimension	2200 x 642 x 1455mm

### Feature

- High precision: The label belt detour deviation rectifying mechanism is designed to ensure that the label will not deviate to left or right during process of traction;
- No manual real-time supervision is required: before using up of label roll, the machine acousto-optically reminds the operator to change label roll automatically to avoid production delay due to lack of label.
- Simple label changing operation: the design of all mechanisms of labeling head is fully considered for convenience of label installing, resulting in time saving of installing label and increasing production efficiency;
- Streamlined delivery design: using design of inner angle and streamline in the process of label conveying to avoid stripped labels during conveying before labeling under situations such as hard labels, insufficient label glue or cold weather etc., reducing production risk and promoting production efficiency;
- Automatic bottle splitting mechanism, suitable for round products which can not stand.

### Scope Of Application

- Products required to label on upper plane, concave and large curved surface.

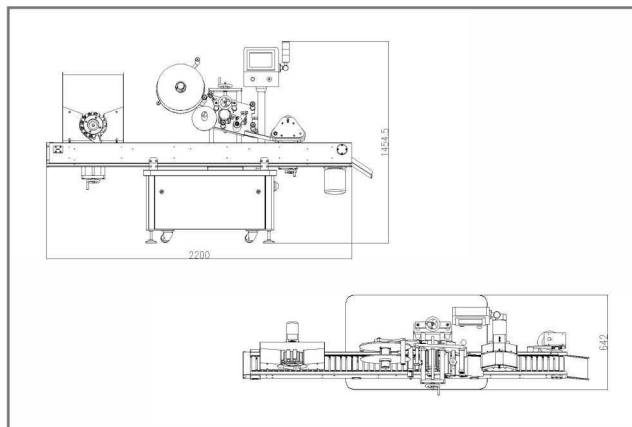

# SF-3010 平面贴标机

## SF-3010 Plane Labeling Machine



### 特点

- 采用先进的人机界面操作, PLC操作;
- 采用不锈钢和铝合金制作, 外形美观、大方;
- 电眼检测, 同步器追踪, 确保出标速度与输送速度精确同步;
- 无需人工实时监管: 标签卷用完前, 机器自动声光提醒操作人员更换标签卷, 避免缺标。

### 适用范围

- 适用于在各种平面物体表面贴标签。

### Scope Of Application

- It is suitable for labeling on the surface of various flat objects.

### 主要技术参数 Technical Data

项目 Items	SF-3010
贴标精度 Labeling precision	±1.0mm
贴标速度 Labeling speed	10~60瓶/分(bottles/min)
标签卷宽度(W) Width of label roll	10~130mm
电源 Power	AC220V 50/60HZ 1KW
主机尺寸 Host dimension	2011x 642 x 1454mm

### Feature

- Adopt advanced human-computer interface operation, and PLC operation;
- Adopt advanced stainless steel and aluminum alloy, with a beautiful appearance.
- Electric eye detection, synchronizer tracking, to ensure the precise synchronization of bidding speed and conveying speed;
- No manual real-time supervision is required: before using up of label roll, the machine aousto-optically reminds the operator to change label roll automatically to avoid lack of label.

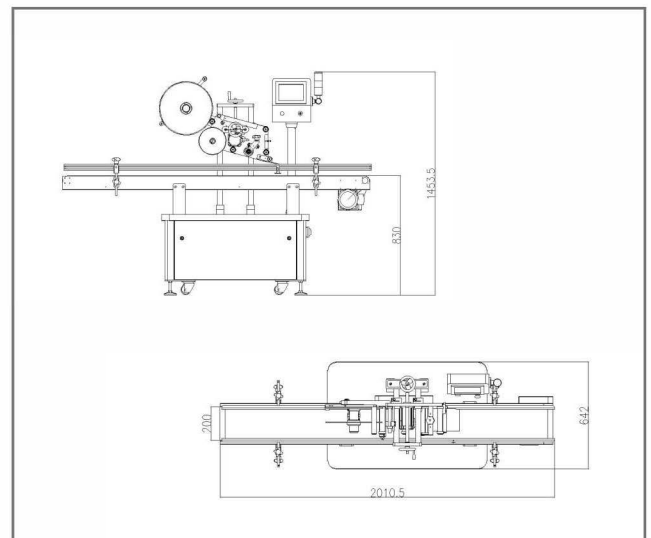

# SF-3042 全自动星盘定点定位圆瓶贴标机

SF-3042 Automatic Static Fixing Round Bottle Labeling Machine



星盘定点定位机构  
Astrolabe fixed point positioning mechanism



## 特点

- 采用先进的人机界面操作, PLC控制;
- 主要用于对有定点定位要求的圆瓶或圆柱形物体进行贴标;
- 304不锈钢外观结构, 三色警示灯工作状态指示, 整机美观大方;
- 贴标速度快, 贴标性能稳定。

## 适用范围

- 适合大多数圆瓶或圆柱形物体的贴标。

## 主要技术参数 Technical Data

项目 Items	SF-3042
贴标精度 Labeling precision	±1.0mm
贴标速度 Labeling speed	30~80瓶/分 bottles/min
圆瓶直径 Round bottle diameter	Ø40mm~Ø110mm
卷标内径 Internal diameter of standard coil	Ø76mm
标签卷外径 Outer diameter of label roll	100~350mm
标签卷宽度 Width of label roll	10~130mm
标签卷长度 Label roll length	15~300mm
电源 Power	AC220V 50/60HZ 800W
主机尺寸 Host dimension	2000 x 1080 x 1456mm

## Feature

- Advanced HMI operation, PLC control;
- It is mainly used for labeling of round bottles or cylindrical objects with static fixing requirements.
- It has the 304 stainless steel structure and three-color indicating light showing working status; the whole machine is beautiful and decent.
- Fast labeling speed, stable labeling performance

## Scope Of Application

- It applies to labeling of most round bottles or cylindrical objects.

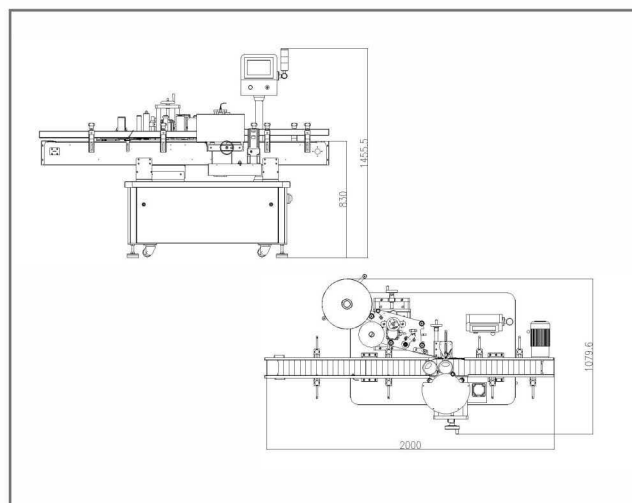



# SFJH-10 全自动浆糊贴标机

## SFJH-10 Automatic paste labeling machine

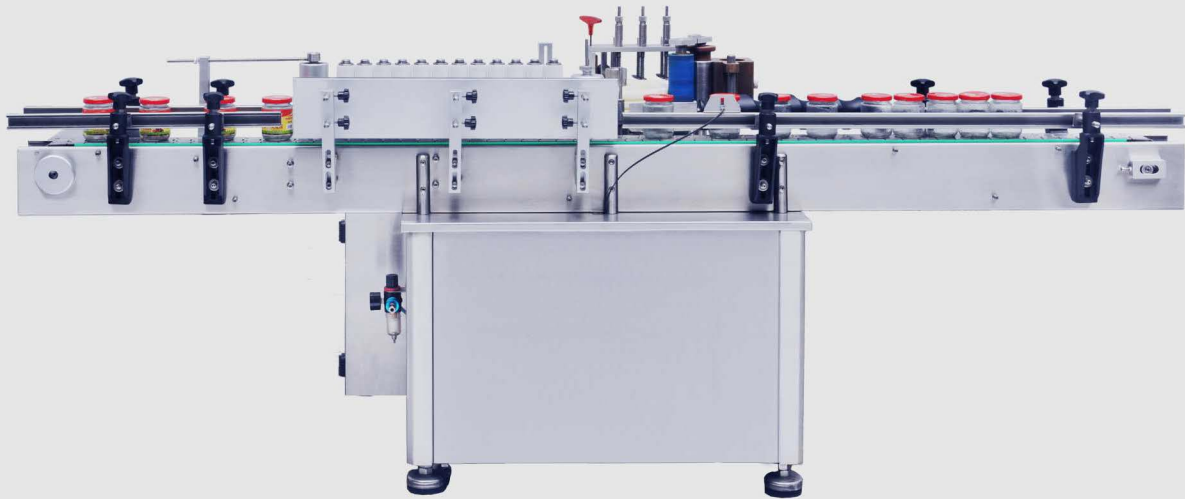

### 特点

- 整体控制面板, 采用304不锈钢, 铝合金设计制作, 拆装简单;
- 标签和贴标速度调整简单, 设有光电检测, 无瓶不送标, 外形美观;
- 操作方便, 省胶水, 贴标平整准确;
- 根据标签规格更换皮带与滚轮, 模块化更换部件, 易于操作。

### 适用范围

- 适用于玻璃瓶浆糊贴标。

### Feature

- Integrated control panel, 304 stainless steel, aluminum alloy design and manufacturing, simple assembly and disassembly
- Simple adjustment of labels and labeling speed; it is equipped with photoelectric detection labels; such labels will not be delivered if bottles are not available. The surface is aesthetic.
- It is easy for operation and glue-saving. Labeling is correct and flat.
- Replace the belt and rollers according to label specifications modular replacement of parts, which is easy for operation.

### Scope Of Application

- It applies to paste labeling of glass bottles.

### 主要技术参数 Technical Data

项目 Items	SFJH-10
贴标精度 Labeling precision	$\geq \pm 1\text{mm}$
贴标尺寸 Labeling dimension	宽(W): 15-120mm 长(L): 15-350mm
标签卷内径 Inner diameter of label roll	$\Phi 76\text{mm}$
贴标速度 Labeling speed	0~80瓶/分(bottles/min)
粘着液 Adhesive liquid	聚醋酸乙烯乳液 Polyvinyl acetate emulsion
电源 Power	AC220V/380V 50/60HZ $\leq 0.37\text{KW}$
重量 Weight	400kg
气压范围 Pressure range	0.4-0.6Mpa
主机尺寸 Host dimension	2400 x 950 x 1000mm

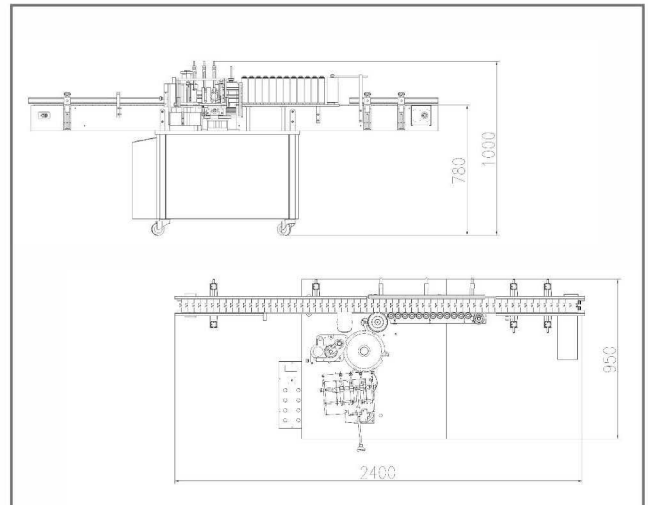

## XBLP-150 高速理瓶机

High-speed bottle sorting machine



### 特点

- 本机采用PLC和西门子触摸屏控制, 人机界面, 一机多用, 不用换模具, 可以理多种瓶型;
- 适用于灌装前道工序, 可将杂乱无章PET塑料瓶排列整齐的输送到生产线上;
- 特殊结构提升系统, 入瓶率高, 瓶损率低;
- 本机机体采用304L不锈钢, 设备核心电气元件、气动系统主关件为名牌产品, 性能更加稳定, 可靠性高。

### 适用范围

- 适用瓶型: 圆瓶、方瓶、扁瓶、曲线瓶、锥形瓶、异形瓶;
- 广泛适用于饮料、日化、制药等行业。

### Scope Of Application

- Applicable to bottle type: round bottle, square bottle, flat bottle, curve bottle, conical bottle, shaped bottle;
- Widely used in beverage, daily chemical, pharmaceutical and other industries.

### 主要技术参数 Technical Data

项目 Items	XBLP-150
瓶子规格(容积) Bottle specification	300~1000ml
速度 Speed	50~150瓶/分 bottles/min
电源 Power	AC220 50/60HZ 1KW
气压范围 Pressure range	0.4-0.6Mpa

### Feature

- The machine adopts PLC and Siemens touch screen control, man-machine interface, multi-purpose one machine, no need to change the mold, can manage a variety of bottle;
- Suitable for the early filling process, can be messy PET plastic bottles arranged neatly transported to the production line;
- Special structure lifting system, high bottle feeding rate, low bottle loss rate;
- The machine body adopts 304L stainless steel, the core electrical components of the equipment and the main pneumatic system are famous brand products, with more stable performance and high reliability.

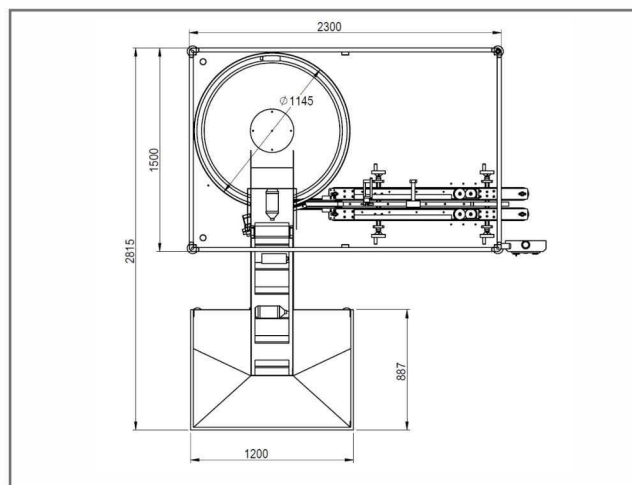



## XBLP-100 理瓶机

XBLP-100 Bottle unscrambler

### 主要技术参数 Technical Data

项目 Items	XBLP-100
电源 Power	AC 220V 50/60HZ 0.24KW
瓶子规格 Bottle specification	15-120ml
速度 Speed	50~120瓶/分 0-150/BPM
主机尺寸 Host dimension	1950 x 900 x 1000mm

## 提升式理盖机 Lifting type cover machine



## XBSP-1200 送瓶机 XBSP-1200 Bottle feeding machine



### 主要技术参数 Technical Data

项目 Items	XBSP-600	XBSP-800	XBSP-1000	XBSP-1200
瓶身 Body of bottle	Φ20-Φ100mm			
瓶子高度 Height of bottle	30-250mm			
电源 Power	AC 220V 50/60HZ 250W		AC 220V 50/60HZ 550W	
速度 Speed	15转/分 4000-5000bs/hr			

### 主要技术参数 Technical Data

项目 Items	提升式理盖机
电源 Power	AC 220V 50/60HZ 380W
速度 Speed	50-120瓶/分 bottles/min
主机尺寸 Host dimension	750 x 1286 x 2347mm

## XBGD 八工位给袋机

### XBGD Eight station bag feeding machine



**XBGD-60 八工位给袋机(单袋)**  
XBGD-60 Eight station bag feeding machine(single bag)

#### 特点

- 间歇式8工位旋转机, 专为平面袋和自立袋(拉链式或无拉链式)包装设计; 触摸屏操作, 简单方便, 出错信息直观显示;
- 符合卫生标准, 清洗方便;
- 多种填充装置可供选择: 螺杆称量填充装置, 量杯填充装置, 液体填充装置, 膏体填充装置以及其它特殊产品的填充装置。

#### 适用范围

- 食用、医用、日化等平面袋、拉链袋、自立袋等袋式包装;
- 适合用于粉剂、颗粒、液体和膏体充填包装。

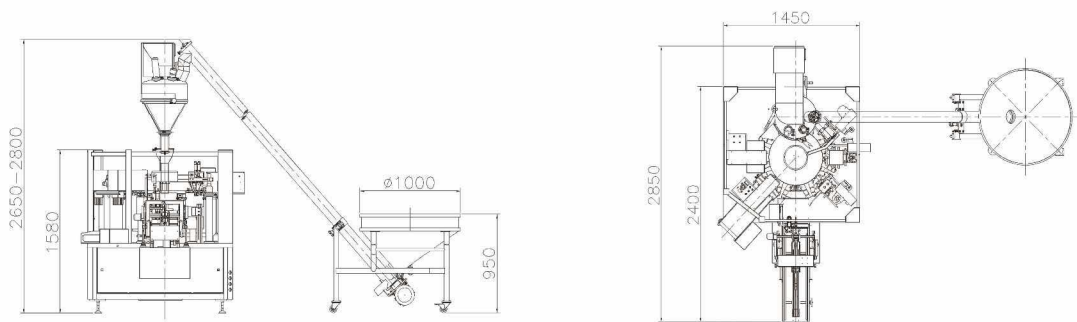

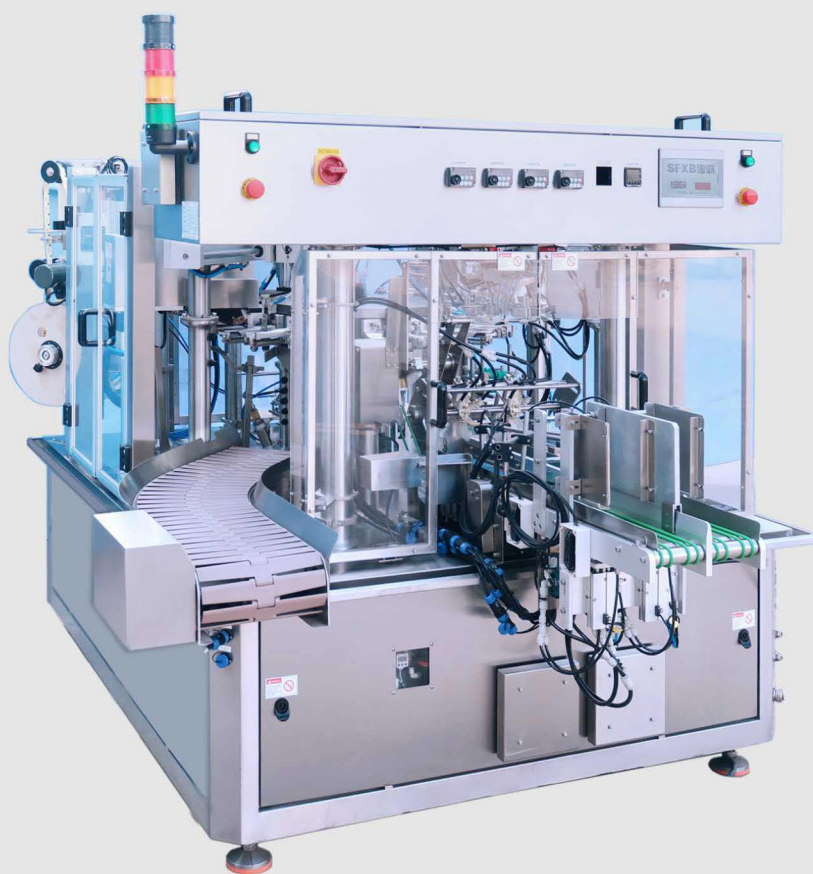

**XBGD-80 八工位给袋机(双袋)**  
Eight-station automatic bag feeder (double bags)



**双袋仓 (一次供两袋)**  
Double bag bin (for two bags at a time)



**双袋干燥剂投包**  
Double bags of desiccant package

### Feature

- Intermittent rotary machine with 8 Stations is designed for handling Pre-made pouches such as Flat and Stand-up Pouches (with/ without Zip). Operating and adjusting via TOUCH SCREEN, fault indication on the TOUCH SCREEN.
- Hygienic Construction and Easy cleaning.
- Various filling devices are available: screw weighing device, measuring cup filling device, liquid filling device, paste filling device and other special products filling device

### Scope Of Application

- It applies to bag packaging of plane bags, zippered bags and self-standing bags for food, medical purpose and daily use chemicals.
- It can be used for power, particle, liquid and liquid cream filling packaging.

### 主要技术参数 Technical Data

项 目 Items	XBGD-60	XBGD-80
适用袋质 Applicable bag material	OPP/CPP,OPP/CE,PET/PE等复合材料	
适用袋型 Applicable bag type	平面袋、自立袋、拉链袋、风琴袋、壶嘴袋等 Flat bag, stand-up bag, zipper bag, organ bag, spout bag, etc	
袋子尺寸 Bag size	K(L) 130-350mm 宽(W) 100-250mm	K(L) 120-250mm 宽(W) 100-150mm
主要驱动结构 Main driving structure	Indexing Gear Box分割器	
生产能力 Production capacity	30-60ppm	40-80ppm
电 源 Power	AC220V 50/60HZ 4.5KW	AC220V 50/60HZ 5.2KW
气压范围 Pressure range	200N liter/min,0.6Mpa	

## 八工位给袋机典型应用图例 Doypack machine typical application

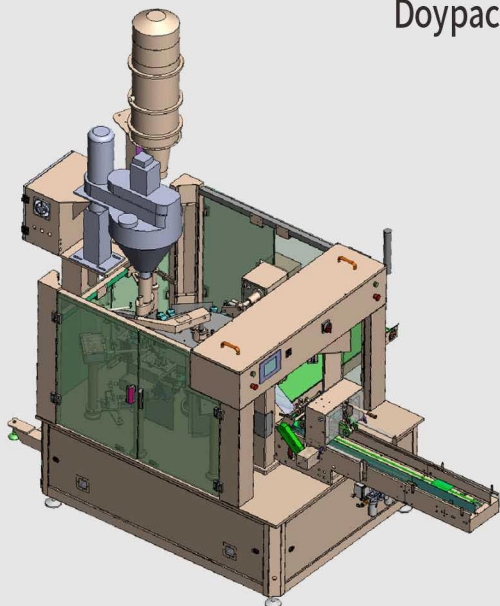

**用伺服螺杆充填包装粉剂产品**  
Screw auger system for powder

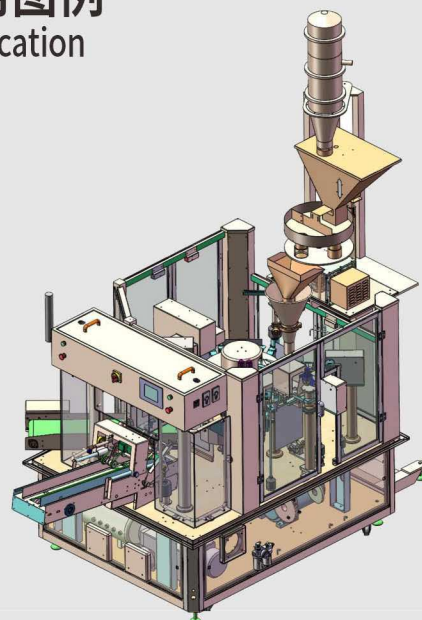

**用旋转量杯填充系统包装颗粒产品**  
Volumetric cup system for granule

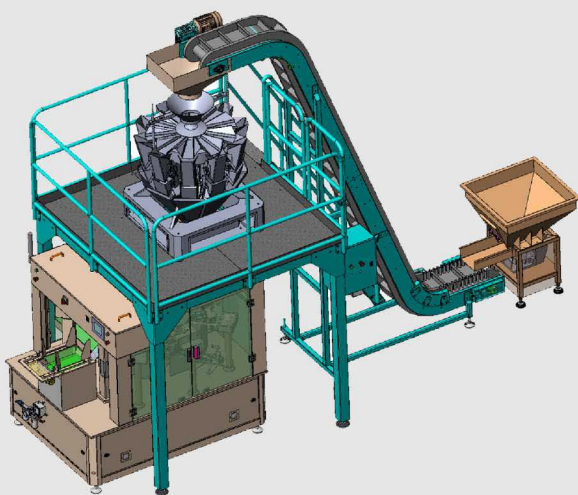

**用电子组合充填系统包装块状产品**  
Multi head scale system for granule

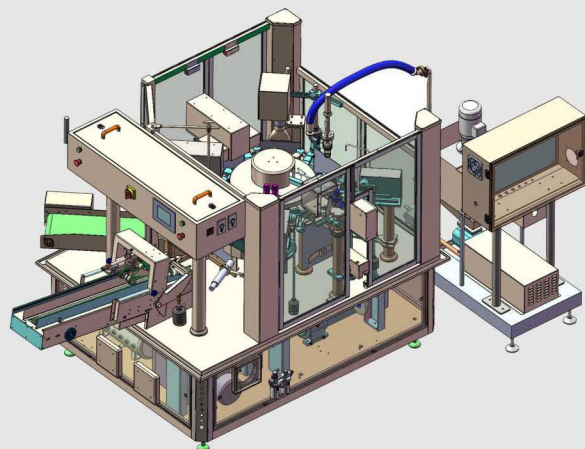

**用转子泵填充包装酱料产品**  
Rotary lobe pump system for liquid

### 应用类型

- 粉剂: 小麦粉、汤料 (螺栓称量填充装置);
- 颗粒: 砂糖、种子 (两杯容积填充装置);
- 液体: 清洁剂、洗发水、漂洗剂, 饮料 (活塞泵或螺旋泵);
- 膏体: 软罐头食品 (特殊螺旋泵或回转泵)。

### Application

- Powder: wheat flour, soup (bolt weighing filling device);
- Particles: sugar, seeds (two cups volume filling device);
- Liquid: detergent, shampoo, rinse agent, beverage (piston pump or screw pump);
- Paste: soft canned food (special screw pump or rotary pump).

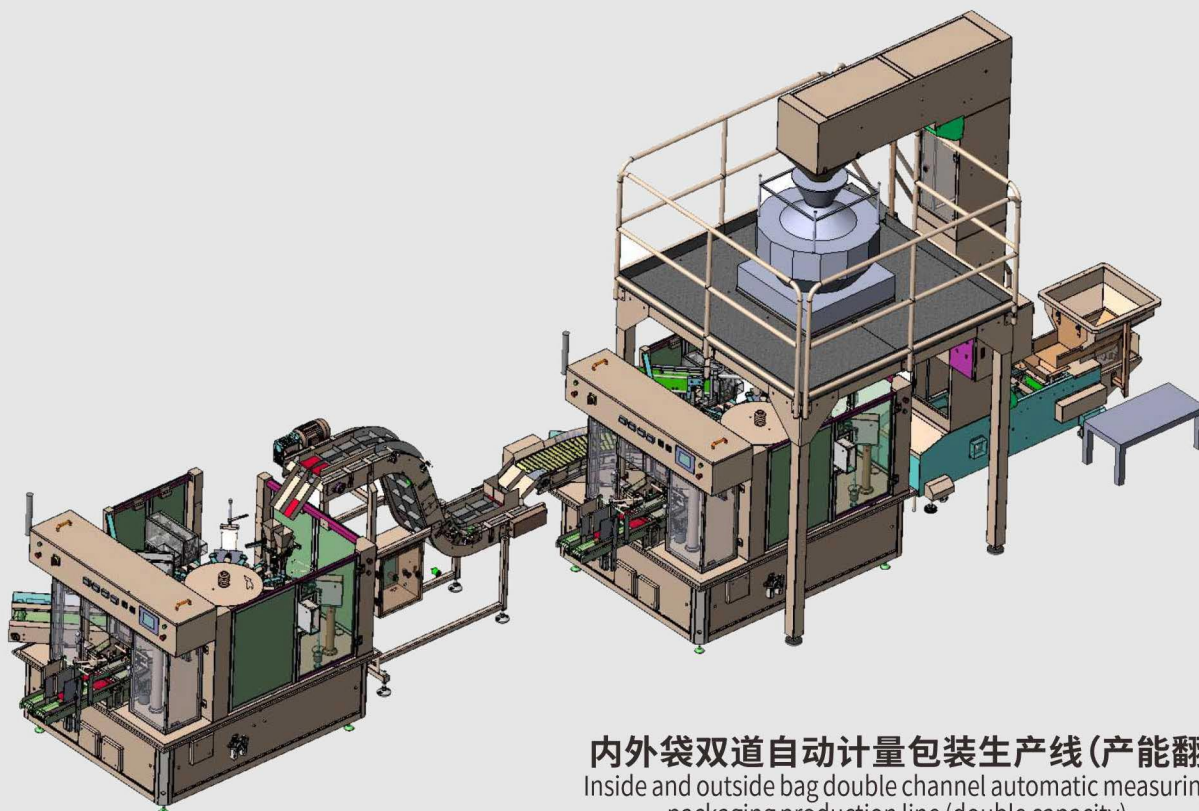

**内外袋双道自动计量包装生产线 (产能翻倍)**  
 Inside and outside bag double channel automatic measuring packaging production line (double capacity)

### 工作程序

- ① 给袋
- ② 打码, 开拉链 (选项)
- ③ 开自立袋
- ④ 上开袋
- ⑤ 一次充填
- ⑥ 二次充填 (选项)
- ⑦ 热封口
- ⑧ 冷却/输出

### Work procedures

- ① To bags
- ② Coding and unzipping (option)
- ③ Opening the self-reliance bag
- ④ Opening the bag
- ⑤ Firstly filling
- ⑥ Secondary filling (option)
- ⑦ Hot sealing
- ⑧ Cooling/ Outputing

### 适用袋子类型 Applicable packaging bag type



# 秉持精湛技术 跨越世界巅峰

Uphold The Pinnacle Of Technical Excellence Across The World

**SFXB雪霸®**

**广州雪霸专用设备有限公司**

GUANGZHOU XUEBA SPECIAL EQUIPMENT CO.,LTD.

地址：广州市南沙区大岗镇北龙路100号丰盛科苑B7栋

Add: B7 Building, Fengsheng Industrial Park, No. 100 of Beilong Road,  
Dagang Town, Nansha District, Guangzhou, Guangdong, China.

电话 TEL: 0086-020-84999703 84991597 39273262 39273592

(总机) 0086-020-34982803

传真 FAX: 020-84991597

Http: // [www.gzsfbz.com](http://www.gzsfbz.com) 邮编 P.C:511470

E-mali: [sfdqzb@163.com](mailto:sfdqzb@163.com)/[sfdqzb@yahoo.com](mailto:sfdqzb@yahoo.com)

2022.02版



请扫描二维码登录